

Lubricant feed pump P253 DC Smart

for progressive lubrication systems with Bluetooth



Created on: **27.11.2025**

Document no.: **951-171-056-EN**

Version: **05**



Read these instructions before installation or start-up of the product and keep them readily available for later consultation!

Original EC Declaration of Incorporation in accordance with Directive 2006/42/EC, Appendix II Part 1 B

The manufacturer hereby declares at its sole responsibility that the partly completed machinery conforms to the essential health and safety requirements of the Machinery Directive 2006/42/EC, Annex I, marked in the Annex to the EC Declaration of Incorporation as applicable and fulfilled at the time of placing on the market.

The special technical documents were prepared following Annex VII part B. Upon justifiable request, these special technical documents can be forwarded electronically to the respective national authorities. The authorized company for the compilation of the technical documentation is the manufacturer.

Designation: Electrically operated pump P253 for the supply of lubricants within a centralized lubrication system
Type: P253 DC Smart
Item number: 644-xxxxx-x / 6440-xxxxxxx

Furthermore, the following directives and standards were applied in the respective applicable areas:

2006/42/EC: Machinery Directive

2011/65/EU: RoHS II

2014/53/EU: Radio Equipment Directive

EN ISO 12100:2010 EN 60204-1:2018 EN 809:1998+A1:2009/AC:2010

EN 61000-6-2:2005/AC:2005 EN 61000-6-4:2007/A1:2011

EN IEC 63000:2018

EN 301 489-1 v2.1.1 EN 301 489-17 v3.1.1 EN 300 328 v2.1.1

The partly completed machinery must not be put into service until it has been established that the machinery into which it is to be incorporated is in compliance with the provisions of the Machinery Directive 2006/42/EC and all other applicable Directives.

Walldorf, 28.11.2025

Viktoria Wannags
ALS Engineered
Solutions Manager



Martin Zverina
Factory Manager
Chodov



Manufacturer: SKF Lubrication Systems Germany GmbH, Heinrich-Hertz-Str. 2-8, DE - 69190 Walldorf

Original UK Declaration of incorporation according to the Supply of Machinery (Safety) Regulations 2008 No. 1597 Annex II

The manufacturer hereby declares under sole responsibility that the partly completed machinery complies with the essential health and safety requirements of UK legislation Supply of Machinery (Safety) Regulations 2008 No. 1597 Annex I, marked in the Annex to the EC Declaration of Incorporation as applicable and fulfilled at the time of placing on the market.

The special technical documents were prepared following Annex VII part B. Upon justifiable request, these special technical documents can be forwarded electronically to the respective national authorities. The authorized company for the compilation of the technical documentation is SKF (U.K.) Limited, 2 Canada Close, Banbury, Oxfordshire, OX16 2RT, GBR.

Designation: Electrically operated pump P253 for the supply of lubricants within a centralized lubrication system
Type: P253 DC Smart
Item number: 644-xxxxx-x / 6440-xxxxxxx

Furthermore, the following regulations and standards were applied in the respective applicable areas:

Supply of Machinery (Safety) Regulations 2008 No. 1597

The Restriction of the Use of Certain Hazardous Substances in Electrical and Electronic Equipment Regulations 2012 No. 3032

Radio Equipment Regulations 2017 No. 1206

EN ISO 12100:2010 EN 60204-1:2018 EN 809:1998+A1:2009/AC:2010

EN 61000-6-2:2005/AC:2005 EN 61000-6-4:2007/A1:2011

EN IEC 63000:2018

EN 301 489-1 v2.1.1 EN 301 489-17 v3.1.1 EN 300 328 v2.1.1

The partly completed machinery must not be put into service until it has been established that the machinery into which it is to be incorporated is in compliance with the provisions of UK legislation Supply of Machinery (Safety) Regulations 2008 No. 1597 and all other applicable Directives.

Walldorf, 28.11.2025

Viktoria Wannags
ALS Engineered
Solutions Manager



Martin Zverina
Factory Manager
Chodov



Manufacturer: SKF Lubrication Systems Germany GmbH, Heinrich-Hertz-Str. 2-8, DE - 69190 Walldorf

Appendix to Declaration of Incorporation in accordance with 2006/42/EC, Annex II, No. 1 B

Description of the essential health and safety requirements according to 2006/42/EC, Annex I, which have been applied and fulfilled. Any essential health and safety requirements not listed here are not relevant to this product.

Table 1

**Appendix to Declaration of Incorporation
Valid for: P253 - lubricant feed pumps**

No.:	Essential health and safety requirement	Applicable:	Fulfilled:
1.1.1	Definitions	Yes	Yes
1.1.2	Principles of safety integration	Yes	Yes
1.1.3	Materials and products	Yes	Partially ¹⁾
1.1.5	Design of machinery to facilitate its handling	Yes	Yes
1.1.6	Ergonomics	Yes	Partially ²⁾
1.2	Control systems	Yes	Yes
1.2.1	Safety and reliability of control systems	Yes	Yes
1.2.3	Starting	Yes	Yes
1.2.6	Failure of the power supply	Yes	Yes
1.3	Protection against mechanical hazards	Yes	Yes
1.3.1	Risk of loss of stability	Yes	Yes
1.3.2	Risk of break-up during operation	Yes	Partially ³⁾
1.3.4	Risks due to surfaces, edges or angles	Yes	Yes
1.3.7	Risks related to moving parts	Yes	Yes
1.3.9	Risks of uncontrolled movements	Yes	Yes
1.5	Risks due to other hazards	Yes	Yes
1.5.1	Electricity supply	Yes	Yes
1.5.6	Fire	Yes	Yes
1.5.8	Noise	Yes	Yes
1.5.11	External radiation	Yes	Yes
1.5.13	Emissions of hazardous materials and substances	Yes	Yes
1.5.15	Risk of slipping, tripping, or falling	Yes	Yes
1.6	Servicing		
1.6.1	Machinery maintenance	Yes	Yes
1.6.2	Access to operating positions and servicing points	Yes	Partially ⁴⁾
1.6.4	Operator interventions	Yes	Yes
1.7	Information	Yes	Yes
1.7.1	Information and warnings on the machinery	Yes	Yes
1.7.1.1	Information and information devices	Yes	Yes
1.7.2	Warning of residual risks	Yes	Yes
1.7.3	Marking of machinery	Yes	Yes
1.7.4	Operating instructions/assembly instructions	Yes	Yes
1.7.4.1	General principles for the drafting of operating instructions/assembly instructions	Yes	Yes
1.7.4.2	Contents of the operating instructions/assembly instructions	Yes	Yes
1.7.4.3	Sales literature	Yes	Yes

- 1) Not completely fulfilled: Hazards due to the lubricant used must be assessed by the operator on the basis of the Safety Data Sheet (SDS) and, if necessary, protective measures must be taken.
- 2) Not completely fulfilled: The operator must ensure that the pump is integrated into the higher-level machine in such a way that the pump can be operated and filled ergonomically.
- 3) Not completely fulfilled: The operator must protect the lubrication system against excessive pressure. For this purpose, a pressure limiting valve with max. 270 bar opening pressure must be provided on each pump element.
- 4) Not completely fulfilled: The operator must ensure that the pump is integrated into the higher-level machine in such a way that the pump can be operated without danger.

Masthead

Manufacturer

SKF Lubrication Systems Germany GmbH
Email: Lubrication-germany@skf.com
www.skf.com/lubrication

Berlin Plant
Motzener Strasse 35/37
12277 Berlin
Germany
Tel. +49 (0)30 72002-0
Fax +49 (0)30 72002-111

Walldorf Plant
Heinrich-Hertz-Strasse 2-8
69190 Walldorf, Germany
Germany
Tel.: +49 (0) 6227 33-0
Fax: +49 (0) 6227 33-259

Authorized local distributors

- Great Britain -
SKF (U.K.) Limited,
2 Canada Close, Banbury, Oxfordshire,
OX16 2RT, GBR.

- North America -
SKF Lubrication Business Unit
Lincoln Industrial
5148 North Hanley Road, St. Louis,
MO. 63134 USA

- South America -
SKF Argentina Pte. Roca 4145,
CP 2001 Rosario, Santa Fe

Warranty

The instructions contain no statements regarding the warranty or liability for defects. That information can be found in our General Terms of Payment and Delivery.

Training

We conduct detailed training in order to enable maximum safety and efficiency. We recommend taking advantage of this training. For further information, contact your authorized SKF dealer or the manufacturer.

Table of contents

Original EC Declaration of Incorporation in accordance with Directive 2006/42/EC, Appendix II Part 1 B	2
Original UK Declaration of incorporation according to the Supply of Machinery (Safety) Regulations 2008 No. 1597 Annex II.....	2
Masthead	4
Table of contents.....	5
Safety alerts, visual presentation, and layout	7
1 Safety instructions.....	8
1.1 General safety instructions.....	8
1.2 General electrical safety instructions	8
1.3 General behaviour when handling the product	8
1.4 Intended use	8
1.5 Persons authorized to use the product.....	8
1.6 Foreseeable misuse	9
1.7 Referenced documents.....	9
1.8 Prohibition of certain activities	9
1.9 Painting plastic components and seals.....	9
1.10 Possible safety markings on the product.....	9
1.11 Note on the type plate	9
1.12 Notes on CE marking	10
1.13 Note on Low Voltage Directive	10
1.14 Note on Pressure Equipment Directive.....	10
1.15 Note on ECE mark.....	10
1.16 Note on UKCA marking	10
1.17 Note on EAC marking.....	10
1.18 Note on China RoHS mark.....	10
1.19 Note on the wireless module	10
1.20 Emergency shutdown	10
1.21 Assembly, maintenance, fault, repair	11
1.22 First start-up, daily start-up.....	11
1.23 Residual risks.....	12
2 Lubricants.....	13
2.1 General information	13
2.2 Material compatibility.....	13
2.3 Temperature properties	13
2.4 Aging of lubricants.....	13
2.5 Avoidance of faults and hazards	13
2.6 Solid lubricants	13
2.7 Chisel pastes.....	13
3 Overview, functional description.....	14
3.1.1 Pumps without a follower plate	14
4 Technical data	16
4.1 General technical data.....	16
4.2 Nominal delivery rates.....	17
4.2.1 Influencing factors on the delivery rate	17
4.2.2 Delivery rate charts for typical NLGI 2 lubricants	18
4.3 Principle of operation of the intermittent low-level signal.....	19
4.4 Operational limits of the intermittent empty signal	20
4.5 Hydraulic connection diagrams.....	21
4.6 Usable reservoir volume	22
4.6.1 Usable reservoir volume for reservoirs without a follower plate (2 – 15 liters).....	22
4.6.2 Usable reservoir volume for reservoirs with a follower plate (4 – 15 liters).....	22
4.6.3 Usable reservoir volume for reservoirs with double-lip follower plate (4 – 25 liters).....	22
4.7 Lubricant volume when an empty pump is filled for the first time.....	22
4.8 Tightening torques.....	23
4.9 Type identification code.....	24
4.9.1 Basic parameters and reservoir design	24
4.9.2 Pump elements.....	26
4.9.3 Power supply and electrical connections	27
4.9.4 Control and lubricant.....	29
4.10 Standard grease KF LGCC 2.....	30
5 Delivery, returns, storage.....	31
5.1 Delivery	31
5.2 Return shipment.....	31
5.3 Storage	31
5.4 Storage temperature range.....	31
5.5 Storage conditions for products filled with lubricant	31
5.5.1 Storage period up to 6 months	31
5.5.2 Storage period between 6 and 18 months ...	31
5.5.3 Storage period more than 18 months	31
5.6 Declaration of decontamination.....	31
6 Assembly	32
6.1 General safety instructions	32
6.2 Transporting the pumps.....	32
6.3 Mechanical connection.....	33
6.3.1 Minimum mounting dimensions.....	33
6.3.2 Assembly holes	34
6.3.3 Assembly holes for 15 l, 20 l, and 25 l reservoirs.....	35
6.4 Electrical connection	36
6.5 Setting the delivery rate on pump element R.....	37
6.6 Installing the pressure limiting valve.....	38
6.7 Connection of the lubrication line	39
6.8 Filling with lubricant.....	39
6.8.1 Filling via the reservoir cover	39
6.8.2 Filling via filler nipple.....	40
6.8.3 Initial filling with double-lip follower plate ...	40
6.9 Initial filling of an empty pump with follower plate	40
7 First start-up.....	42
7.1 Inspections before first start-up	42
7.2 Inspections during first start-up.....	42
8 Operation	43
8.1 Top up lubricant	43
8.2 Triggering additional lubrication	43
9 Maintenance	44
10 Cleaning.....	45
10.1 Basics	45
10.2 Interior cleaning	45
10.3 Exterior cleaning.....	45
11 Faults, causes, and remedies.....	46
12 Repairs	47
12.1 Replacing pump element and pressure limiting valve.....	47
13 Shutdown, disposal.....	47
13.1 Temporary shutdown.....	47
13.2 Permanent shutdown, disassembly.....	47
13.3 Disposal	47
14 Spare parts	48
14.1 Housing cover, complete.....	48

14.2 Pump elements.....	48
14.3 Pressure limiting valves and adapters.....	48
14.4 Adapter D6 AX 1/8NPT I C	49
14.5 Motor 12 / 24 V DC.....	49
14.6 Adapter with filler nipple.....	49
14.7 Closure screw	49
14.8 Transparent reservoir.....	50
14.9 Fixed paddle.....	51
14.10 Reservoir cover	51
15 Appendix.....	52
15.1.1 Terminal diagram for full and low-level signals on the reservoir cover.....	52
15.1.2 Overview of cables and possible connections	53
15.1.3 Terminal diagram for P253_x-xxXCxx-xxx-xH- 00200000M000-CMxxxx	55
15.1.4 Terminal diagram for P253_x-xxXCxx-xxx-xH- A0000000K000-CMxxxx	56
15.1.5 Terminal diagram for P253_x-xxYCxx-xxx-xH- F0C00000I0Y0-CMxxxx	57
15.1.6 Terminal diagram for P253_x-xxXCxx-xxx-xH- 00700000M000-CMxxxx	58

Safety alerts, visual presentation, and layout

While reading these instructions, you will encounter various symbols, illustrations, and text layouts intended to help you navigate and understand the instructions. Their meaning is explained below.

Safety alerts:

Activities that present specific hazards (to life and limb or possible damage to property) are indicated by safety alerts. Always be sure to follow the instructions given in the safety alerts.

DANGER

These safety alerts indicate an imminent danger. Ignoring them will result in death or serious injury

WARNING

These safety alerts indicate potentially imminent danger. Ignoring them could result in death or serious injury

CAUTION

These safety alerts indicate potentially imminent danger. Ignoring them could result in minor injury

NOTICE

These safety alerts indicate a potentially harmful situation. Ignoring them could result in damage to property or malfunctions

Illustrations:

The illustrations used depict a specific product. For other products, they may have the function of a diagram only. This does not alter the basic workings and operation of the product.

Text layout:

- **First-order bulleted lists:** Items on a bulleted list start with a solid black dot and an indent.
 - **Second-order bulleted lists:** If there is a further listing of subitems, the second-order bulleted list is used.
- 1 **Legend:** A legend explains the numbered contents of an illustration, presented as a numbered list. Items in a legend start with a number (with no dot) and an indent.
 - **Second-order legend:** In some cases, the numbered contents of an image represent more than just one object. A second-order legend is then used.
- 1. **Instruction steps:** These indicate a chronological sequence of instruction steps. The numbers of the steps are in bold and are followed by a period. If a new activity follows, the numbering starts again at “1.”
 - **Second-order instruction steps:** In some cases, it is necessary to divide up a step into a few substeps. A sequence of second-order instruction steps is then used.

1 Safety instructions

1.1 General safety instructions

- Putting the products into operation or operating them without having read the instructions is prohibited. The operator must ensure that the instructions are read and understood by all persons tasked with working on the product or who supervise or instruct such persons. Retain the instructions for further use.
- The product may only be used in awareness of the potential dangers, in proper technical condition, and according to the information in this manual.
- Any faults that could affect safety must be remedied according to responsibility. The supervisor must be notified immediately in case of malfunctions outside one's individual scope of responsibility.
- Unauthorized modifications and changes can have an unpredictable effect on safety and operation. Unauthorized modifications and changes are therefore prohibited. Only original SKF spare parts and SKF accessories may be used.
- Any unclear points regarding proper condition or correct assembly/operation must be clarified. Operation is prohibited until issues have been clarified.
- The components used must be suitable for the intended use and the applicable operating conditions, e.g. max. operating pressure and ambient temperature range, and must not be subjected to torsion, shear, or bending.

1.2 General electrical safety instructions

- Electrical devices must be kept in proper condition. This must be ensured by periodic inspections in accordance with the relevant applicable standards and technical rules. The type, frequency, and scope of the inspections must be determined in accordance with the risk assessment to be carried out by the operator. Work on electrical components may be performed only by qualified electricians. Connect the electrical power only in accordance with the valid terminal diagram and in observance of the relevant regulations and the local electrical supply conditions.
- Work on electrical components may be performed only in a voltage-free state and using tools suitable for electrical work. Do not touch cables or electrical components with wet or moist hands.
- Fuses must not be bridged. Always replace defective fuses with fuses of the same type.
- Ensure proper connection of the protective conductor for products with protection class I. Observe the specified enclosure rating.
- The operator must implement appropriate measures to protect vulnerable electrical devices from the effects of lightning during use. The electrical device is not furnished with a grounding system for the dissipation of the respective electric charge and does not have the voltage strength necessary to withstand the effects of lightning.

1.3 General behaviour when handling the product

- Familiarize yourself with the functions and operation of the product. The specified assembly and operating steps and their sequences must be observed.
- Keep unauthorized persons away.
- Wear personal protective equipment always.
- Precautionary operational measures and instructions for the respective work must be observed.
- In addition to these Instructions, general statutory regulations for accident prevention and environmental protection must be observed.
- Precautionary operational measures and instructions for the respective work must be observed. Uncertainty seriously endangers safety.
- Safety-related protective and safety equipment must not be removed, modified or affected otherwise in its function and is to be checked at regular intervals for completeness and function.
- If protective and safety equipment has to be dismantled, it must be reassembled immediately after finishing the work, and then checked for correct function.
- Remedy occurring faults in the frame of responsibilities. Immediately inform your superior in the case of faults beyond your competence.
- Never use parts of the centralized lubrication system or of the machine as standing or climbing aids.

1.4 Intended use

Supply of lubricants.

The product is intended solely for installation in another machine.

Use is only permitted within the scope of commercial or economic activity by professional users, in compliance with the specifications, technical data, and limits specified in this manual.

1.5 Persons authorized to use the product

Operator

A person who is qualified by training, knowledge and experience to carry out the functions and activities related to normal operation. This includes avoiding possible hazards that may arise during operation.

Specialist in electrics

Person with appropriate professional education, knowledge and experience to detect and avoid the hazards that may arise from electricity.

Specialist in mechanics

Person with appropriate professional education, knowledge and experience to detect and avoid the hazards that may arise during transport, installation, start-up, operation, maintenance, repair and disassembly.

1.6 Foreseeable misuse

Any usage of the product other than as specified in this manual is strictly prohibited. Particularly prohibited are:

- Use of non-specified consumables, contaminated lubricants, or lubricants with air inclusions.
- Use of C3 versions in areas with aggressive, corrosive substances (e.g., high salt load).
- Use of plastic parts in areas with high exposure to ozone, UV light, or ionizing radiation.
- Use to supply, convey, or store hazardous substances and mixtures as defined in the CLP Regulation (EC 1272/2008) or GHS with acute oral, dermal, or inhalation toxicity or substances and mixtures that are marked with hazard pictograms GHS01-GHS06 and GHS08.
- Use to supply, convey, or store Group 1 fluids classified as hazards as defined in the Pressure Equipment Directive (2014/68/EU) Article 13 (1) a).
- Use to supply, convey, or store gases, liquefied gases, dissolved gases, vapors, or fluids whose vapor pressure exceeds normal atmospheric pressure (1013 mbar) by more than 0.5 bar at their maximum permissible operating temperature.
- Use in an explosion protection zone.
- Use without proper securing against excessively high pressures, in the case of pressurized products.
- Use outside of the technical data and limits specified in this manual.

1.7 Referenced documents

In addition to this manual, the following documents must be observed by the respective target group:

- Company instructions and approval rules
If applicable:

- Safety data sheet of the lubricant used
- Project planning documents
- Supplementary information regarding special designs of the pump. This you will find in the special system documentation.
- Instructions for other components for setting up the centralized lubrication system.

1.8 Prohibition of certain activities





The following activities must be performed only by employees of the manufacturer or authorized persons due to possibly undetectable sources of error or due to statutory requirements:

- Repairs or modifications to the drive.
- Alterations to the control circuit board beyond adjustment of lubrication times and interval times or replacement in case of defect.

1.9 Painting plastic components and seals

The painting of any plastic components and seals of the products described is prohibited. Completely mask or remove plastic components before painting the main machine.

1.10 Possible safety markings on the product

	Risk of dangerous electrical voltage (with VAC products only)
	Risk of being drawn into machinery by the stirring paddle when the reservoir cover is open (only for reservoirs with filling from above)
	Risk of injury from spring tension (only in pumps with a follower plate)
	Direction of rotation of the pump (stirring paddle)
	Read the instructions. Before initial filling of a pump delivered without lubricant. (Only for pumps with a double-lip follower plate)

Possible safety markings on the product

NOTE

Further to the findings of the workplace risk evaluation the operating company has to attach additional markings (e. g. warnings, signs giving orders, prohibition signs or labelling as specified by CLP / GHS), where appropriate.

1.11 Note on the type plate

The type plate provides important data such as the type designation, order number, and sometimes regulatory characteristics. To avoid loss of this data in case the type plate becomes illegible, it should be entered in the manual.

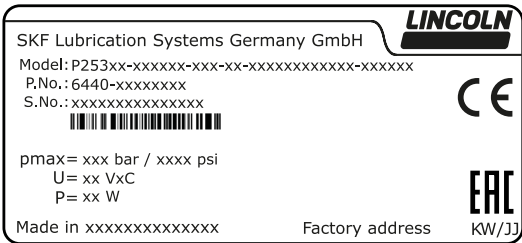
	
Made in xxxxxxxxxxxxxxx	Factory address KW/JJ

Type plate

Fig. 3

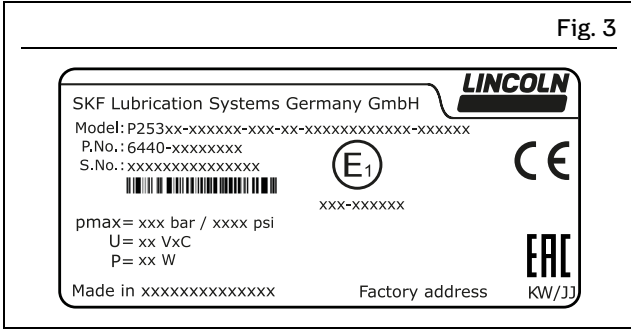

Type plate with ECE mark

1.12 Notes on CE marking



CE marking is effected following the requirements of the applied directives requiring a CE marking:

2014/53/EU: Radio Equipment Directive
2011/65/EU: RoHS II

1.13 Note on Low Voltage Directive

The protection objectives of the Low Voltage Directive 2014/35/EU are met in accordance with Annex I, No. 1.5.1 of the Machinery Directive 2006/42/EC.

1.14 Note on Pressure Equipment Directive

Due to its performance characteristics, the product does not reach the limit values defined in Article 4, Paragraph 1, Subparagraph (a) (ii) and is excluded from the scope of Pressure Equipment Directive 2014/68/EU in accordance with Article 1, Paragraph 2 Subparagraph (f).

1.15 Note on ECE mark



The ECE test mark (E1) confirms that an ECE type approval (components requiring approval on motor vehicles) has been granted for a product which bears this mark on its type plate.

1.16 Note on UKCA marking



The UKCA conformity marking confirms the product's conformity with the applicable legal provisions of Great Britain.

1.17 Note on EAC marking



The EAC conformity marking confirms the product's conformity with the applicable legal provisions of the Eurasian customs union.

1.18 Note on China RoHS mark



The China RoHS mark confirms that there is no danger to persons or the environment from the regulated substances contained within for the intended period of use (year number shown in the circle).

1.19 Note on the wireless module

The wireless module installed in this product complies with the requirements of the USA (FCC) and Canada (ISED). The certification numbers can be found on the corresponding label on the outside of the product.

Fig. 4

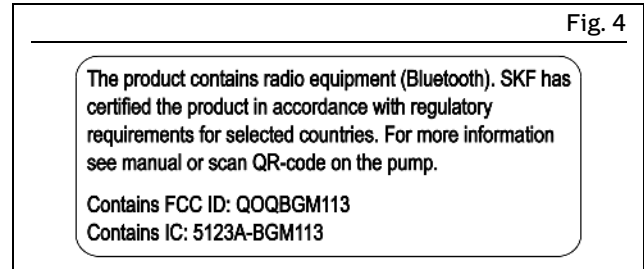

Wireless module certification number

NOTE

Note that the pump versions with Bluetooth can only be operated in countries and regions for which the wireless module is certified. You can check this certification at skf.com/ or by scanning the QR code shown here or the QR code on the pump.



1.20 Emergency shutdown

This is done by a course of action to be defined by the operator.

1.21 Assembly, maintenance, fault, repair

Prior to the start of this work, all relevant persons must be notified of it. At a minimum, the following safety measures must be taken before any work is done:

- Unauthorized persons must be kept away
- Mark and secure the work area
- Cover adjacent live parts
- Dry any wet, slippery surfaces or cover them appropriately
- Cover hot or cold surfaces appropriately

Where applicable:

- Depressurize
- Isolate, lock and tag out
- Check to ensure live voltage is no longer present
- Ground and short-circuit.

The product should be protected as much as possible from humidity, dust, and vibration, and should be installed so that it is easily accessible. Ensure an adequate distance from sources of heat or cold. Any visual monitoring devices present, such as pressure gauges, min./max. markings, or oil level gauges must be clearly visible. Observe the mounting position requirements.

Drill required holes only on non-critical, non-load-bearing parts of the operator's infrastructure. Use existing holes where possible. Avoid chafe points. Immobilize any moving or detached parts during the work. Adhere to the specified torques.

If guards or safety devices need to be removed, they must be reinstalled immediately following conclusion of work and then checked for proper function.

Check new parts for compliance with the intended use before using them.

Avoid mixing up or incorrectly assembling disassembled parts. Label parts. Clean any dirty parts.

1.22 First start-up, daily start-up

Ensure that:

- All safety devices are fully present and functional
- All connections are properly connected
- All parts are correctly installed
- All warning labels on the product are fully present, visible, and undamaged
- Illegible or missing warning labels are immediately replaced.

1.23 Residual risks

			Table 2						
Residual risks									
Residual risk	Possible in lifecycle						Avoidance / Remedy		
Personal injury / property damage due to falling of hoisted parts.	A	B	C		G	H	K	Unauthorized persons must be kept away. Nobody is allowed to be present below hoisted parts. Lift parts using suitable lifting gear.	
Personal injury / property damage due to tilting or falling product due to non-compliance with specified torques.		B	C		G			Adhere to the specified torques. Mount the product only on components with a sufficient load-carrying capacity. If no torques are specified, use those specified for the screw size for screws of strength class 8.8.	
Personal injury, property damage due to spilled, leaked lubricant.		B	C	D	F	G	H	K	Be careful when connecting or disconnecting the lubricant lines. Use only hydraulic screw unions and lubrication lines suitable for the specified pressure. Do not mount lubrication lines on moving parts or chafe points. If this cannot be avoided, use anti-kink coils and/or conduits.
Fire hazard or damage to the pump from operation with damaged electrical components, such as power leads and plugs.		B	C	D	E	F	G	H	Inspect electrical components for damage prior to initial use and then at regular intervals. Do not install the cable on moving parts or chafe points. If this cannot be avoided, use anti-kink coils and/or conduits.
Damage to the pump from failure to comply with the permissible relative ON-time.			C	D					Operate the pump only within the permissible relative ON-time.
Damage to the pump from installing at the place of use without the mounting brackets and fastening hardware intended for that purpose (see Installation chapter).		B	C	D		G			Install the pump only with the mounting brackets and fastening hardware intended for that purpose.

Lifecycle phases: A = Transport, B = Assembly, C = First start-up, D = Operation, E = Cleaning, F = Maintenance, G = Malfunction, repair, H = Shutdown, K = Disposal

2 Lubricants

2.1 General information

Lubricants are selected specifically for the relevant application. The manufacturer or operator of the machine should ideally make the selection in consultation with the supplier of the lubricant. If you have no or little experience in selecting lubricants for lubrication systems, please contact us. We would be happy to assist you in selecting suitable lubricants and components to build a lubrication system optimized for your particular application. Consider the following points when selecting/using lubricants. This will spare you potential downtime and damage to the machine or lubrication system.

2.2 Material compatibility

The lubricants must generally be compatible with the following materials:

- Plastics: ABS, CR, FPM, NBR, NR, PA, PET, PMMA, POM, PP, PS, PTFE, PU, PUR
- Metals: steel, gray cast iron, brass, copper, aluminum.

2.3 Temperature properties

The lubricant used must be suitable for the specific ambient temperature of the product. The viscosity approved for proper functioning must neither be exceeded at low temperatures nor fall too low at high temperatures. For the approved viscosity, see the "Technical data" chapter.

2.4 Aging of lubricants

Based on past experience with the lubricant used, checks should be conducted at regular intervals defined by the operator, to determine whether the lubricant needs to be replaced due to aging processes (oil separation). In case of doubt regarding the continued suitability of the lubricant, it must be replaced before the system is started up again. If you do not yet have any experience with the lubricant used, we recommend conducting a check after just one week.

2.5 Avoidance of faults and hazards

To avoid faults and hazards, please observe the following:

- When handling lubricants, observe the relevant safety data sheet (SDS) and any hazard labeling on the packaging.
- Due to the large number of additives, some lubricants that meet the pumpability requirements specified in the manual are not suitable for use in centralized lubrication systems.
- Whenever possible, always use SKF lubrication greases. They are ideal for use in lubrication systems.
- Do not mix lubricants. This can have unpredictable effects on the properties and usability of the lubricant.
- Use lubricants containing solid lubricants only after technical consultation with SKF.
- The lubricant's ignition temperature has to be at least 50 kelvin above the maximum surface temperature of the components.

2.6 Solid lubricants

Solid lubricants may only be used after prior consultation with SKF. When solid lubricants are used in lubrication systems, the following rules generally apply:

Graphite:

- Maximum graphite content 8%
- Maximum grain size 25 µm (preferably in lamellar form).

MoS₂:

- Maximum MoS₂ content 5%
- Maximum grain size 15 µm.

Copper:

- Lubricants containing copper are known to lead to coatings forming on pistons, bore holes, and mating surfaces. This can result in blockages in the centralized lubrication system.

Calcium carbonate:

- Lubricants containing calcium carbonate are known to lead to very heavy wear on pistons, bore holes, and mating surfaces.

Calcium hydroxide:

- Lubricants containing calcium hydroxide are known to harden considerably over time, which can lead to failure of the centralized lubrication system.

PTFE, zinc, and aluminum:

- For these solid lubricants, it is not yet possible to define any limit values for use in lubrication systems on the basis of existing knowledge and practical experience.

2.7 Chisel pastes

Due to their high resistance to pressure and temperature, chisel pastes are used to reduce wear on insert tools and wear bushings on hydraulic and pneumatic hammers, stone crushers and hydraulic grabs. Before use, observe the safety data sheet (SDS) and the technical data and application limits of the respective chisel paste.

Chisel pastes may be pumped only with SKF pumps and pump elements developed for this application.

Chisel pastes are special lubricants and must not be used as a lubricant for bearings.

Grease guns filled with chisel paste must be permanently marked with a corresponding note.

NOTE

The use of chisel paste requires prior consultation with the SKF Product Management.

3 Overview, functional description

3.1.1 Pumps without a follower plate



Equipment features

Reservoir

The reservoir (Fig. 5/1) stores the lubricant. Different reservoir designs and reservoir sizes exist in accordance with the pump variant.

Reservoir cover

The reservoir cover (Fig. 5/2) is used to fill the reservoir with clean and suitable lubricant, and also to protect the lubricant from contamination.

Reservoir ventilation

The reservoir ventilation (Fig. 5/3) aerates the reservoir while the pump is working and lubricant is being fed.

Pump housing

The pump housing (Fig. 5/4) contains the motor, the electrical connections, the filler nipple, the pump elements, and (if applicable) the intermittent low-level signal.

Pump elements

The pump can be equipped with up to 3 pump elements (Fig. 5/5).

Filler nipple

Used for filling the pump. If the filler nipple (Fig. 5/6) is removed, the external grease return (from the pressure limiting valves on the pump elements) can be connected to this port, using the applicable accessories.

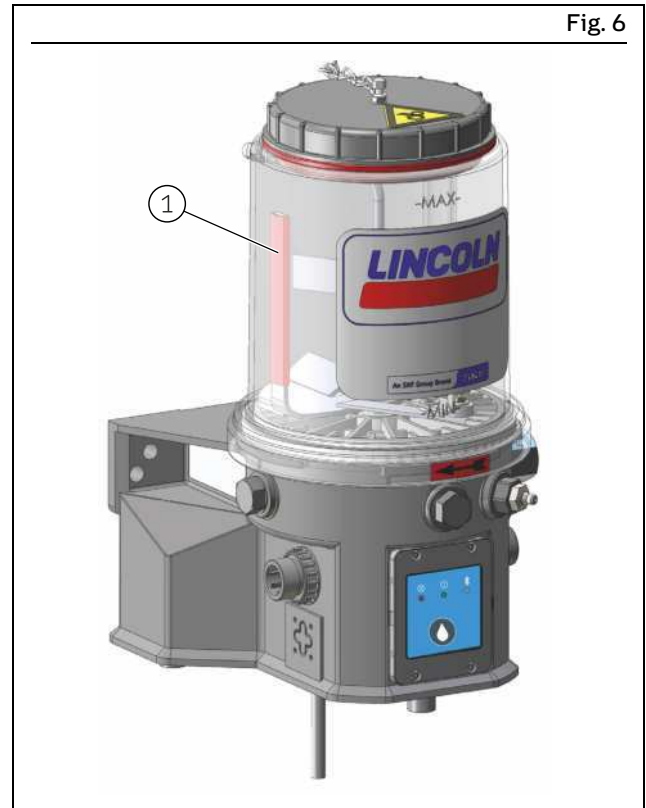

Equipment features

Stirring paddle

The stirring paddle (Fig. 6/1) homogenizes and smooths the lubricant while the pump is running. In addition, the lower vertical part of the stirring paddle presses the lubricant in the direction of the pump elements and improves the suction characteristics of the pump as a result.

3.1.1.1 Electrical connections

(For different connection types, see the type identification code, section 4.9)

Left-hand side:

Fig. 7/1 voltage supply

- Rectangular connector

Fig. 7/2 signal exchange / voltage supply

- M12 plug / socket
- Bayonet connector, 7-pin / 4-pin

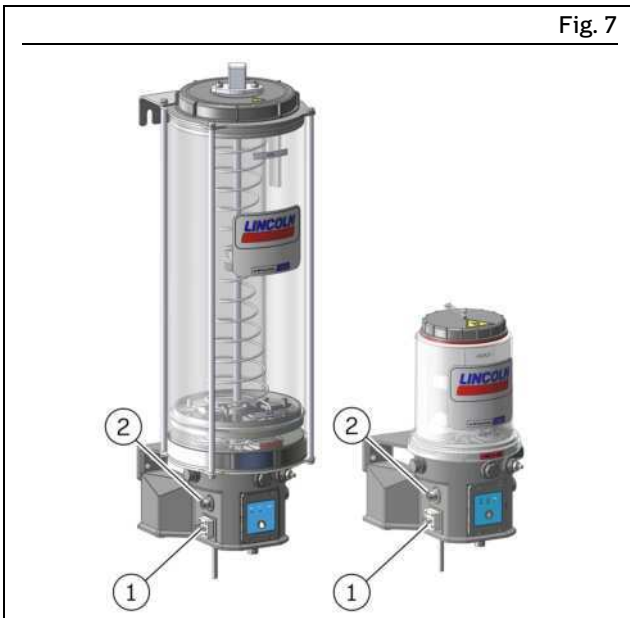

Electrical connections on the left

Right-hand side:

- Bayonet connector, 4-pin (Fig. 8/1) or M12 socket, used for connecting one or two piston detectors.
- PG 9 screwed gland (Fig. 8/2), used for connecting the low-level signal for pumps with a follower plate.

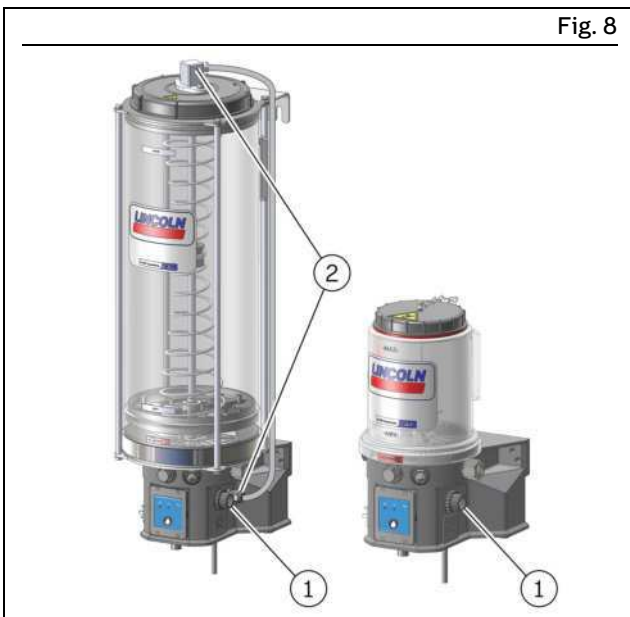

Electrical connections on the right

3.1.1.2 Multifunction pushbutton (Fig. 9/1)

Triggering additional lubrication (Fig. 9/4)

Pressing the multifunction pushbutton briefly during the pause time triggers an additional lubrication. The pump runs until one metering device circulation is complete, and then the pump goes back into the pause time.

Resetting a warning/error message (Fig. 9/4)

If there is an active warning (e.g., reservoir pre-empty signal) or error message (reservoir empty, no signal from the piston detector), it can be acknowledged and reset after remedying the problem, by briefly pressing the multifunction pushbutton during the pause time.

Ending the current operating time (Fig. 9/4)

Pressing the multifunction pushbutton while the pump is running ends the current operating time. The pump is then in pause time.

Indication of operating voltage (Fig. 9/1)

The indicator shows steady green light when sufficient operating voltage is present.

Indication of warning or fault (Fig. 9/2)

In the case of a warning, the indicator flashes red at two-second intervals. In the case of a fault (e.g., low-level signal), the indicator shows a steady red light. When the cause of the warning or fault is eliminated, the signal must be reset by pressing the multifunction pushbutton (Fig. 9/4). When reset, the indicator light goes out.

Indication of Bluetooth (Fig. 9/3)

The indicator shows a blue light when a Bluetooth-enabled SKF pump is connected to the SKF eLube app.

The SKF eLube app can be used to modify the pump settings and to display operating data and Datalogger data. You can find the SKF eLube app in the Apple App Store and the Google Play Store.

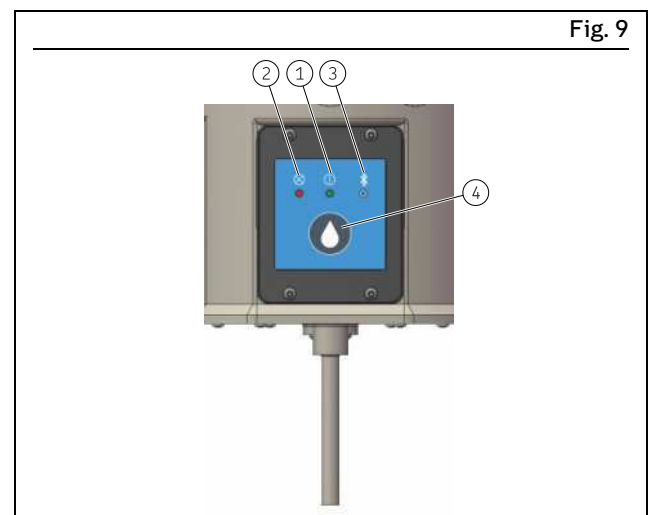

Multifunction pushbutton

4 Technical data

4.1 General technical data

Table 3

Technical data of the pump		
Parameter	Values	
Operating pressure	Max. 350 bar	
Ambient temperature ¹⁾	-40 °C to 60 °C ⁴⁾	
Feedable lubricants ²⁾	Lubricating greases up to and including NLGI 2, lubrication oils with at least 40 mm ² /s (cST) at ambient temperature; for chisel paste, see the Lubricants section	
Pump elements	Max. 3	
Mounting position ³⁾	Upright, i.e., with the reservoir at top	
Sound pressure level	< 70 dB (A)	
Duty cycle	Max. 30 minutes	
Pause time	Min. 3 times the ON-time	
Electrical data of the pump		
Parameter	Values	
	12 VDC pump	24 VDC pump
Rated voltage ±10 %	12 VDC	24 VDC
Current input up to	6 A	3 A
Recommended back-up fuse	6.0 A (slow)	4.0 A (slow)
Motor operating voltage	12 VDC	24 VDC
Enclosure rating ⁵⁾	IP69K	
Protection classes:		
• Rectangular connector / M12x1 connector	SELV / PELV / FELV	
• Bayonet connector / PG9 screwed gland	SELV / PELV	
Nominal speed	20 rpm	
Cyclic duration factor ⁶⁾	S3 25 % duty cycle 120 minutes	
Output signal	Isolated/nonisolated (depending on the connection type)	
Signaling relay:		
• Switching capacity, max.	60 VA	
• Switching voltage, max.	30 VDC	
• Switched current, max.	700 mA	

¹⁾ The specified ambient temperature range requires that the lubricant used can be pumped at the given ambient temperature.

²⁾ Observe the restrictions in the section "Operational limits of the intermittent empty signal."

³⁾ Rotary installation is possible for pumps with a follower plate, e.g., in wind turbines. Maximum speed and maximum distance to the rotational axis can be specified on request. If the pump is expected to be installed in an inclined position: The maximum filling ("MAX" mark) must be reduced in accordance with the inclination to be expected (e.g., with construction or agricultural machinery). The minimum filling ("MIN" mark) must be increased starting with an expected inclination > 30°, otherwise functional impairments may arise due to a reduced amount of lubricant the suction area of the pump.

⁴⁾ UL-certified pumps can only be operated up to a maximum permissible ambient temperature of +60 °C regardless of the loading. In the case of pumps that are not UL-certified, the maximum duty cycle should be reduced with ambient temperatures ≥ +60° C and heavy loading (high pressure).

⁵⁾ The specified enclosure rating of the pump requires the use of IP69K-compatible connection sockets and corresponding cables. If connection sockets and cables with a lower protection rating are used, the lowest of those ratings will apply as the enclosure rating. For the enclosure ratings achievable when using the connection sockets and cable supplied by us, see the "Spare parts" chapter.

⁶⁾ Based on ambient temperature of 60 °C and a mean back pressure of 160 bar on the pump element.

Table 4

Factory setting for metering device circulations	
Parameter	Values
Cycle Time	5 minutes
Metering device circulations:	1 metering device circulation per cycle time
Changes to the settings can be made with the SKF app for monitoring and adjusting Bluetooth-compatible SKF pumps. You can find the SKF app in the Apple App Store and the Google Play Store. Following registration, use of the app is free of charge.	
Pump Password (factory setting)	55555555
Master Password (cannot be changed)	03372260
Weight	
2-liter reservoir, standard filling (0.75 kg)	Approx. 6.5 kg
4-liter reservoir, standard filling (1.5 kg)	Approx. 9.0 kg
8-liter reservoir, standard filling (1.5 kg)	Approx. 10 kg
11-liter reservoir, standard filling (1.5 kg)	Approx. 12 kg
15-liter reservoir, standard filling (1.5 kg)	Approx. 14 kg
20-liter reservoir, standard filling (1.5 kg)	Approx. 16 kg
25-liter reservoir, standard filling (1.5 kg)	Approx. 18 kg

4.2 Nominal delivery rates

NOTE

The specified nominal delivery rates per stroke and pump element refer to NLGI grade 2 lubricating greases at an ambient temperature of 20 °C [68 °F] and a back pressure of 100 bar [1450 psi] at the pump element. Differences in operating conditions or a different pump configuration will lead to changes in the motor speed and thus to a change in the delivery rate per unit of time. If the change in the motor speed necessitates an adjustment to the delivery rate per unit of time, then this will be reasonably accomplished by adjusting the lubrication and pause time setting of the pump.

Table 5

Nominal delivery rate per stroke							
Pump element	L ¹⁾	5	6	7	R	B ²⁾	C ³⁾
Nominal delivery rate per stroke	0.03 ccm	0.10 ccm	0.16 ccm	0.22 ccm	0.04 - 0.18 ccm	0.10 ccm	0.24 ccm

¹⁾ The pump element "L" must only be used to supply lubrication greases of NLGI Grade 00. Observe the restrictions in the section "Operational limits of the intermittent empty signal."

²⁾ The pump element "B" is especially suitable for use in contaminated environments, because the pumped lubricant is conveyed through a bypass hole on the check valve.

³⁾ The pump element "C" is designed only for pumping chisel paste. When using chisel paste, observe the relevant information in the "Lubricants" section.

4.2.1 Influencing factors on the delivery rate

Table 6

Influencing factors on the delivery rate		
Influencing factors	Increasing the delivery rate	Reducing the delivery rate
Ambient temperature	> + 20 °C	< + 20 °C
Consistency class of the lubricating grease	< NLGI 2	N/A
Number of pump elements	N/A	> 1
Back pressure at the pump element	< 100 bar	> 100 bar

4.2.2 Delivery rate charts for typical NLGI 2 lubricants

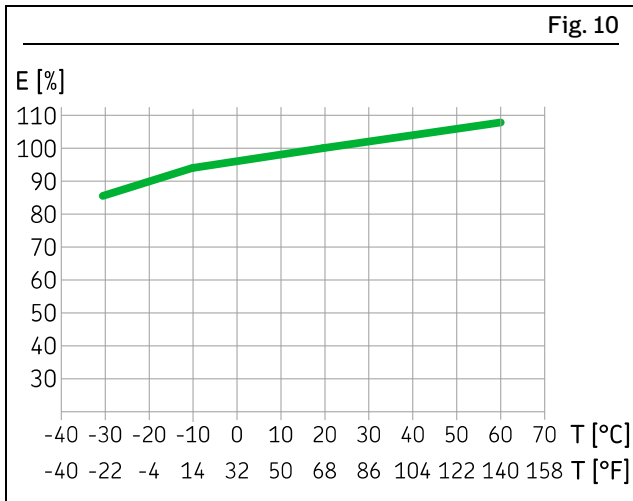

Delivery rate chart for low-temperature grease

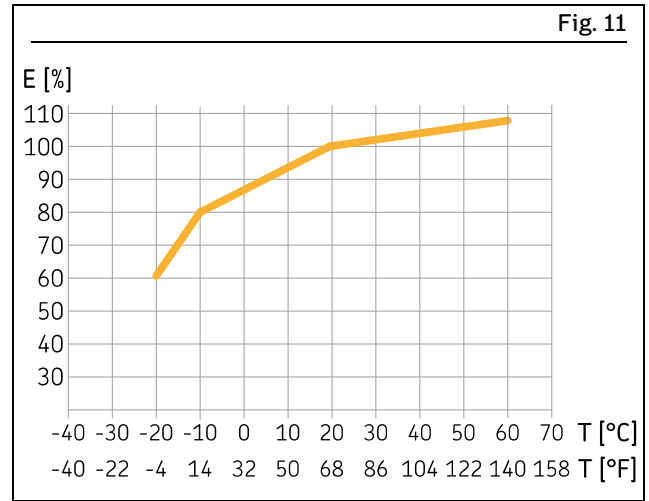

Delivery rate chart for high-temperature grease

NOTE

The values specified in the delivery rate charts represent the average value between different high-temperature and low-temperature greases. The values could therefore vary with the lubrication grease actually used in the pump. This may need to be borne in mind when designing the lubrication system.

Calculation of temperature-dependent delivery rate, using a high-temperature grease as an example

$$OUT = RPM \times V \times E$$

- OUT* Calculated delivery rate per pump element (ccm/min)
- RPM* Nominal speed of the pump (in this example: *RPM* = 20 rpm)
- V* Nominal delivery rate per pump element (in this example: *V* = 0.22 ccm/stroke)
- E* Efficiency as a percentage (in this example: *E* = 80%) at a temperature of *T* = -10 °C)

$$OUT = 20 \frac{1}{min} \times 0,22 \text{ ccm} \times 80 \% = 3,5 \frac{ccm}{min}$$

4.3 Principle of operation of the intermittent low-level signal

Components of the intermittent low-level signal

The intermittent low-level signal uses a contactless mechanism, comprised essentially of the following parts:

- Stationary reed switch (Fig. 12 to 14/1) in the reservoir bottom
- Mobile baffle plate (Fig. 12 to 13/2) connected to the stirring paddle, with a magnet (Fig. 12 to 14/3) and a cam (Fig. 13/4)

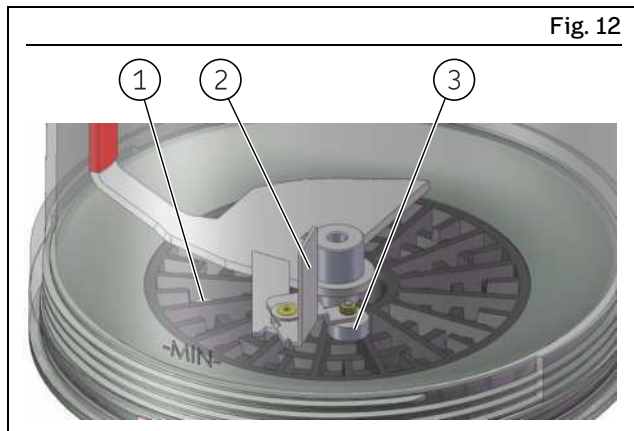

Perspective view

Functional description of the intermittent low-level signal

- 1 When the reservoir is filled with a lubrication grease that is suitable for the intermittent low-level signal, and the pump is running, the baffle plate (Fig. 12 to 13/2) is deflected outwards by the resistance of the lubrication grease.
- 2 As a result, the magnet (Fig. 12 to 14/3) connected to the baffle plate moves along its inner circular path (Fig. 13), which means that it **cannot** trigger a pulse on the reed switch (Fig. 12 to 14/1).
- 3 During each revolution, a cam (Fig. 13/4) forces the magnet and the pivot-mounted baffle plate back out onto the outer circular path (Fig. 14)
- 4 After passing the cam, the resistance of the lubricant pushes the baffle plate and the magnet back inwards, onto the inner circular path.

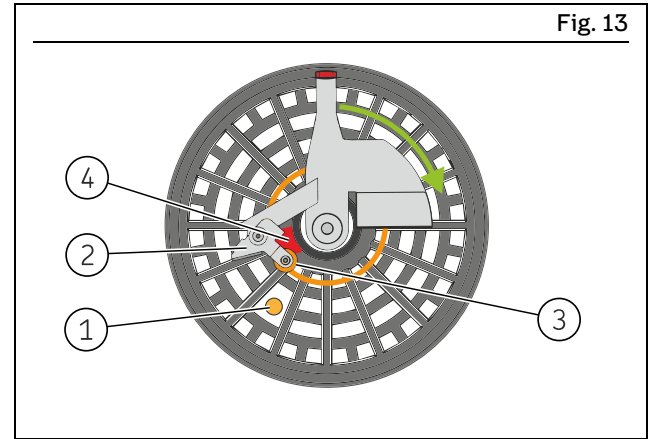

Magnet on inner circular path

- 5 When the lubricant level in the reservoir drops so far that the resistance of the lubrication grease is no longer enough to deflect the baffle plate (Fig. 12 to 13/2), the magnet (Fig. 12 to 14/3) stays on the outer path, triggering a pulse during each revolution as it slides over the reed switch (Fig. 12 to 14/1).
- 6 If the magnet (Fig. 12 to 14/3) moves over the reed switch (Fig. 12 to 14/1) on the outer circular path five times during one work cycle, a low-level signal is output directly on the pump's signal connection.

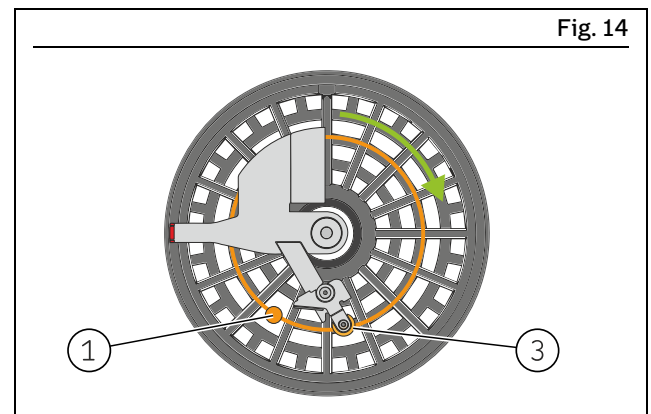

Magnet on outer circular path

4.4 Operational limits of the intermittent empty signal

For the correct functioning of the intermittent empty signal, the following lubricant consistencies must be maintained. The correct functioning of the intermittent empty signal is not guaranteed above the specified temperature range. The lower temperature ranges are contingent on the suitability of the respective lubricant for these temperatures. Excessively high consistency of the lubricant could otherwise lead to malfunctions such as interruption of the lubricant feeding or possibly to damage to the pump (e.g., bending of the stirring paddle).

NOTE

The intermittent empty signal is not suitable for lubricating greases with an NLGI class ≤ 0 .

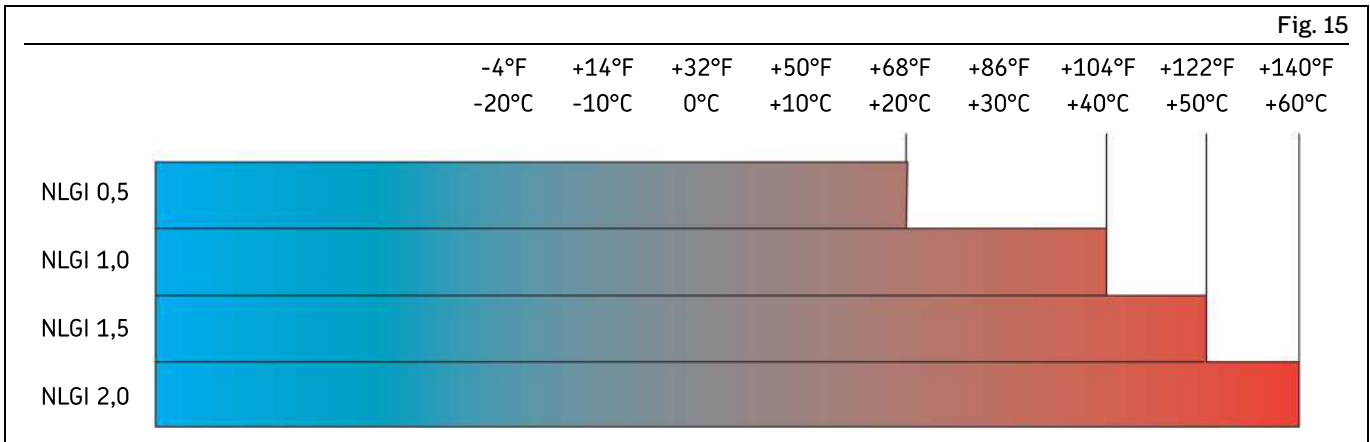

Operational limits of the intermittent empty signal

4.5 Hydraulic connection diagrams

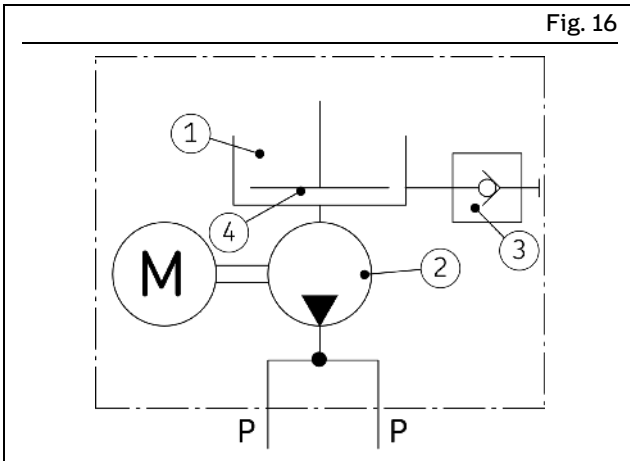

Pump with a follower plate

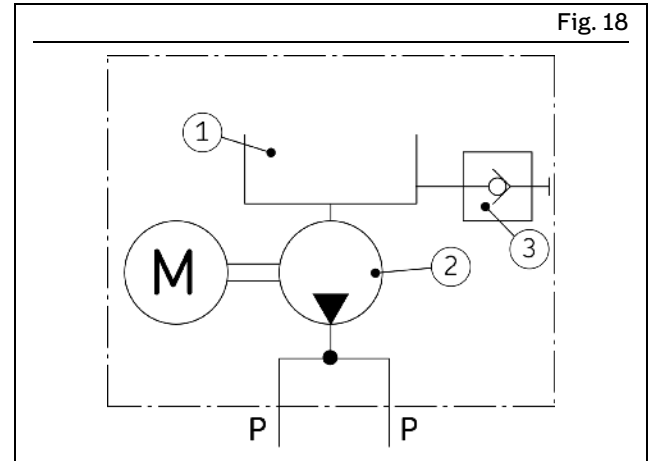

Pump without a follower plate

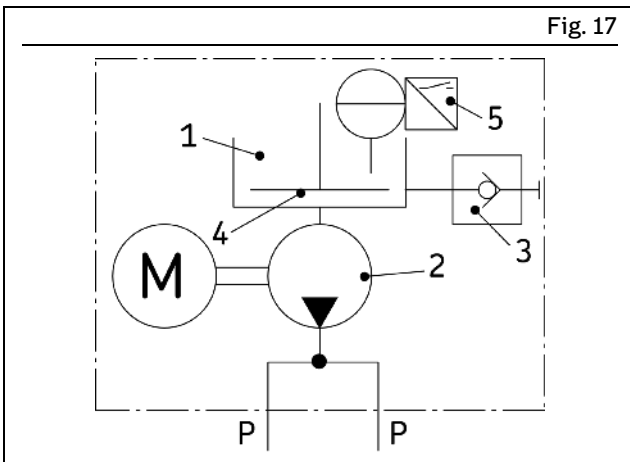

Pump with a follower plate and with low-level signal

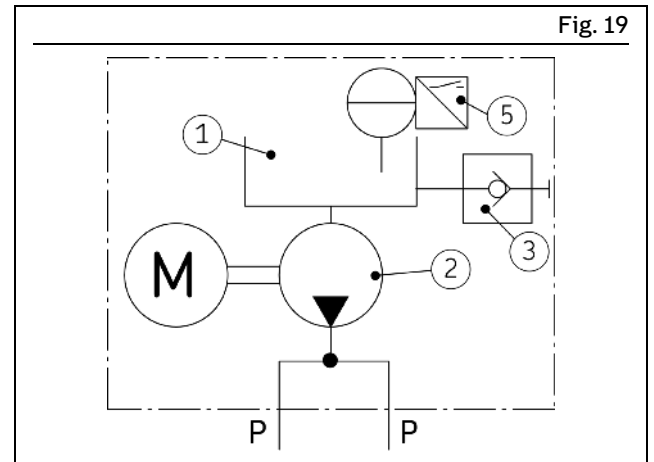

Pump without a follower plate and with low-level signal

Table 7

Legend to Figure

Item	Description
1	Reservoir
2	Pump
3	Filler nipple (or alternatively P)
4	Follower plate
5	Fill level signal for reservoir
P	Pressure line (outlet with pump element)

4.6 Usable reservoir volume

NOTE

The usable reservoir volume in the reservoir design without follower plate is strongly dependent on the consistency (NLGI Grade) of the lubricant used and the ambient temperature. With high consistency and a low working temperature, more lubricant typically adheres to the inner surfaces of the reservoir and the pump, leaving less lubricant available for feeding.

Table 8

4.6.1 Usable reservoir volume for reservoirs without a follower plate (2 – 15 liters)

Reservoir size in liters and [gal.]	2 [0.53]	4 [1.06]	8 [2.11]	11 [2.90]	15 [3.96]
Lubricants with relatively low consistency ^{1), 2)}	1.6 - 2.0 [0.42 - 0.53]	3.35 - 3.85 [0.88 - 1.01]	6.65 - 7.15 [1.76 - 1.88]	8.78 - 9.28 [2.32 - 2.45]	14.35 - 14.90 [3.79 - 3.93]
Lubricants with relatively high consistency ³⁾	1.8 - 2.0 [0.47 - 0.53]	3.65 - 4.15 [0.96 - 1.10]	7.00 - 7.50 [1.84 - 1.98]	9.13 - 9.63 [2.41 - 2.54]	14.75 - 15.25 [3.90 - 4.03]

¹⁾ Consistencies of NLGI 000 lubricants at + 60 °C [140 °F] up to consistencies of NLGI 1.5 lubricants at + 20 °C [68 °F].

²⁾ Consistencies of NLGI 2 lubricants at + 20 °C [68 °F] up to the maximum permissible lubricant consistency.

³⁾ When using lubricants with relatively low consistency in pumps subjected to strong vibrations or tilting motions (e.g., heavy equipment for construction or agriculture), maintain a clearance of about 15 mm [0.59 in.] below the -MAX- mark on the reservoir. This stops lubricant from entering the reservoir bleed screw. In the case of very strong vibrations or large tilting motions, this value must be increased, and can be reduced in the case of lesser vibrations. Changing the filling height by 10 mm [0.4 in.] equates to a change in volume of approx. 0.34 liters [0.09 gal.].

Table 9

4.6.2 Usable reservoir volume for reservoirs with a follower plate (4 – 15 liters)

Reservoir size in liters and [gal.]	4 [1.06]	8 [2.11]	11 [2.90]	15 [3.96]
Usable reservoir volume	3.0 [0.66]	6.4 [1.41]	11.5 [2.53]	15.4 [3.39]

Table 10

4.6.3 Usable reservoir volume for reservoirs with double-lip follower plate (4 – 25 liters)

Reservoir size in liters and [gal.]	4 [1.06]	8 [2.11]	15 [2.90]	20 [4.40]	25 [5.50]
Usable reservoir volume	1.9 [0.42]	5.4 [1.19]	13.9 [3.06]	20.1 [4.42]	25.1 [5.52]

4.7 Lubricant volume when an empty pump is filled for the first time

The following volumes of lubricant are required in order to fill a new empty pump up to the -MAX- mark on the reservoir.

NOTE

The difference between the lubricant volume required for initial filling and the nominal volume of the reservoir is due to the filling of the space in the pump housing up to the -MIN- mark on the reservoir.

Table 11

Lubricant volume when an empty pump is filled for the first time (liters / [gal.])

Reservoir design

Nominal volume	2 [0.53]	4 [1.06]	8 [2.11]	11 [2.90]	15 [3.96]	20 [5.28]	25 [6.60]
Reservoir without follower plate	3.80 ± 0.25 [1 ± 0.07]	5.80 ± 0.25 [1.53 ± 0.07]	9.15 ± 0.25 [2.41 ± 0.07]	12.85 ± 0.25 [2.83 ± 0.07]	17.50 ± 0.25 [4.62 ± 0.07]	-----	-----
Reservoir with follower plate	-----	3.30 ± 0.25 [0.87 ± 0.07]	7.00 ± 0.25 [1.85 ± 0.07]	9.15 ± 0.25 [2.01 ± 0.07]	15.00 ± 0.25 [3.96 ± 0.07]	-----	-----
Reservoir with double-lip follower plate	-----	2.90 ± 0.25 [0.77 ± 0.07]	6.4 ± 0.25 [1.69 ± 0.07]	-----	14.0 ± 0.25 [3.70 ± 0.07]	18.5 ± 0.25 [4.89 ± 0.07]	25.3 ± 0.25 [6.68]

4.8 Tightening torques

Table 12

Tightening torques

Component	Tightening torque
1 Pump element on pump	20 Nm ± 2.0 Nm [14.75 ft.lb. ± 1.4 ft.lb.]
2 Pressure limiting valve on pump element	6 Nm - 0.5 Nm [4.43 ft.lb. - 0.07 ft.lb.]
3 Fastening the pump	18 Nm ± 1.0 Nm [13.27 ft.lb. ± 0.74 ft.lb.]
4 Housing cover (bottom) when replacing	0.75 Nm ± 0.1 Nm [0.55 ft.lb. ± 0.07 ft.lb.]
5 Plug screw or adapter with cone-type grease nipple	10 Nm + 1.0 Nm [7.38 ft.lb. ± 0.7ft.lb.]
Rectangular connector screw (not shown)	0.5 Nm ± 0.1 Nm [0.37 ft.lb. ± 0.01 ft.lb.]

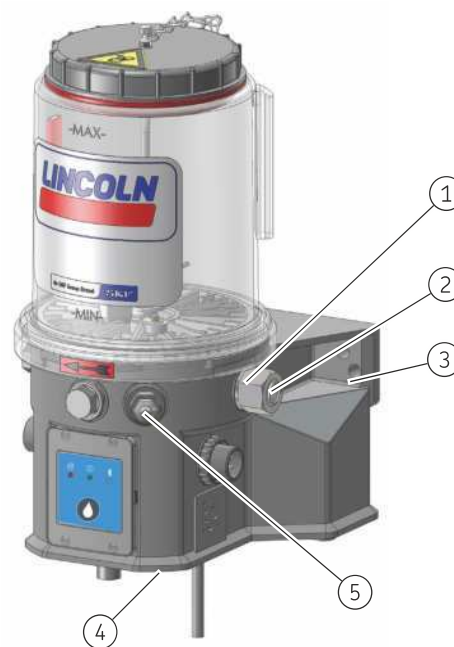

Reservoir design:

(For design combinations, see Table 13)

- BO Filling from above
- BA Filling from above, lockable cover
- FL Flat reservoir
- F Standard follower plate
- D Double-lip follower plate

Table 13

Reservoir designs

Code	Possible reservoir capacities								Description
	2 l	4 l	8 l	11 l	15 l	20 l	25 l		
X N	√	√	√		√				Reservoir for grease , without low-level signal (standard design)
X N FL	√								Flat reservoir for grease , without low-level signal
X N BO	√	√	√	√	√				Reservoir for grease, filling from above without low-level signal
X N BA		√	√						Reservoir for grease with lockable cap, filling from above without low-level signal
X C	√	√	√		√				Reservoir for grease , with low-level signal as NC contact
X C BO	√	√	√	√	√				Reservoir for grease, filling from above with low-level signal as NC contact
X C BA		√	√						Reservoir for grease; filling from above; lockable cover; low-level signal as NC contact
X B F		√	√	√	√				Reservoir for grease , with follower plate and full/low-level signal
X B D		√	√	√	√	√	√		Reservoir for grease , with double-lip follower plate and full/low-level signal
Y N BO	√	√	√		√				Reservoir for oil, filling from above without low-level signal
Y N BA		√	√						Reservoir for oil; filling from above; lockable cover; without low-level signal
Y C BO	√	√	√		√				Reservoir for oil, filling from above with low-level signal (float switch)
Y C BA		√	√						Reservoir for oil; filling from above; lockable cover; low-level signal (float switch)

4.9.2 Pump elements

P253 E - 15 X C BO - 600 -

Pump elements:

Position sequence: Right (Fig. 20/1), Center (Fig. 20/2) and Left (Fig. 20/3).

For coding, see Table 14

Fig. 20

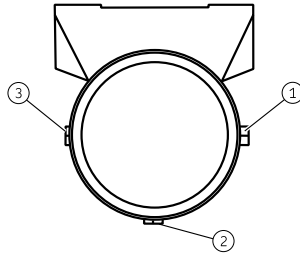

Layout of pump elements

Table 14

Pump elements*

Code	Description
0	Without/no pump element
L	Piston diameter = 5 mm; delivery rate 0.03 ccm (only suitable for grease of NLGI Grade 00)
5	Piston diameter = 5 mm
6	Piston diameter = 6 mm
7	Piston diameter = 7 mm
R	Piston diameter = 7 mm, adjustable pump element
B	Piston diameter = 7 mm, delivery volume equivalent to pump element 5 (piston diameter = 5 mm)
C	Piston diameter = 7 mm, for chisel paste
Thread:	Connection Outlet (lubrication line)
	M22x1.5 G1/4"

* In this category, it is always necessary to make more than one selection.

4.9.3 Power supply and electrical connections

The P253 has six different connection options on the housing. These different connection positions are coded using six two-number groups in the type identification code.

- The first digit in a two-digit number indicates the plug/socket on the housing
- The second digit in a two-number group defines the plug/socket included in the scope of supply

NOTE
See also section 15.

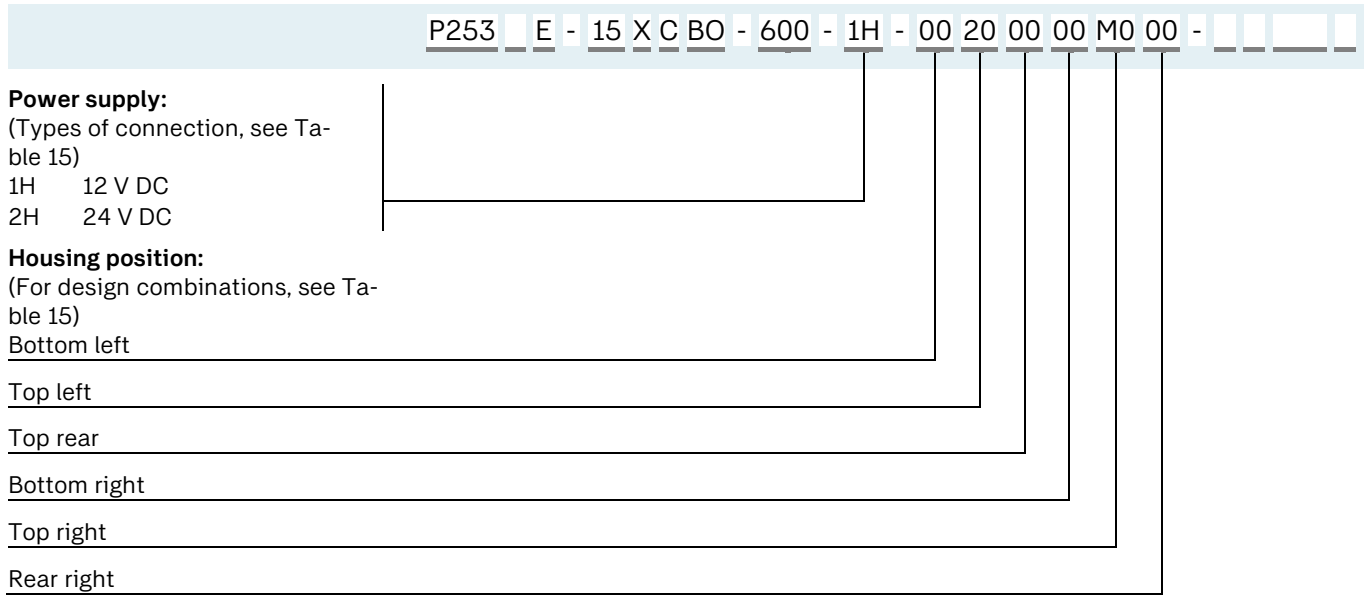

Possible connection types:

Bottom		Left Top		Housing position				Right Top		Rear		Description
I	II	I	II	I	II	I	II	I	II	I	II	
0	-	0	-	0	-	0	-	0	-	0	-	Connection on the pump housing: No connection
A	-	-	-	-	-	-	-	-	-	-	-	Rectangular connector, (IMS mainboard) power supply, remote contact (not in combination with connection type "C")
F	-	-	-	-	-	-	-	-	-	-	-	Rectangular connector, (IMS mainboard) power supply
-	B	-	-	-	-	-	-	-	-	-	-	M12 plug, coding A, nonisolated, additional lubrication, button, voltage supply
-	C	-	-	-	-	-	-	-	-	-	-	Socket M12, coding A, nonisolated, additional lubrication, remote contact, relay, exchange of signals (only in combination with connection type "F")
-	2	-	-	-	-	-	-	-	-	-	-	Bayonet connector, 7-pin, power supply, fault signal, additional lubrication
-	M	-	-	-	-	-	M	-	-	-	-	Bayonet connector, 4/3-pin (1 piston detector)
-	7	-	-	-	-	-	-	-	-	-	-	Bayonet connector, 4/4-pin, (IMS mainboard) power supply, additional lubrication, notification
-	-	E	-	-	-	-	-	-	-	-	-	M12 plug, coding A, 3-pin, floating, signal
-	-	-	-	-	-	-	I	-	-	-	-	M12 socket, coding B (1 piston detector)
-	-	-	-	-	-	-	K	-	-	-	-	M12 socket, coding B (T connector, 2 piston detectors)
-	-	-	-	-	-	-	N	-	-	-	-	Bayonet connector, 4/4-pin (2 piston detectors)
-	-	-	-	-	-	-	-	-	Y ¹⁾	-	-	Screwed gland PG 9 on pump housing and rectangular connector on the reservoir lid (low-level signal)
-	-	-	-	-	-	-	-	-	8 ¹⁾	-	-	Y: 15 l reservoir 8: 2 1/4 l reservoir
-	-	-	-	-	-	-	-	-	9 ¹⁾	-	-	9: 8 l reservoir
-	0	-	0	-	0	-	0	-	0	-	0	Accessories for the connection: Without socket, without cable
-	1	-	-	-	-	-	-	-	-	-	-	With connection socket, without cable

¹⁾ Connection type depends on reservoir capacity

4.9.4 Control and lubricant

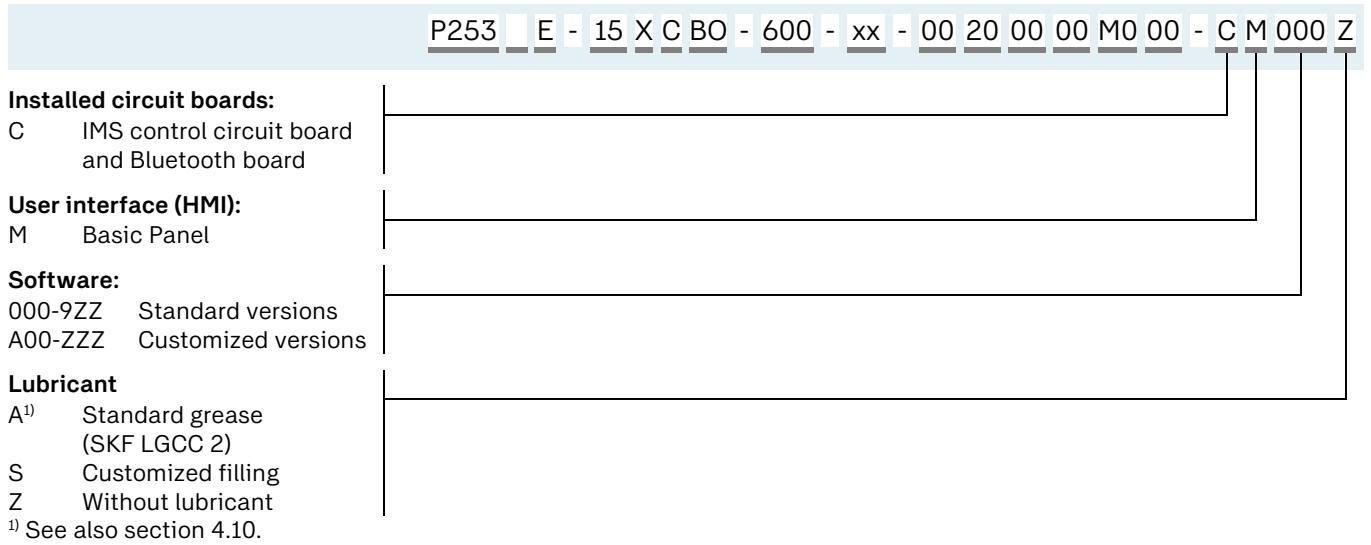

4.10 Standard grease KF LGCC 2

Features

SKF LGCC 2 is a multi-purpose grease that has been specially designed to provide outstanding performance in a broad range of lubrication systems. It performs especially well in environments with very low temperatures. Its advanced composition ensures excellent water resistance and long-lasting corrosion protection.

Table 16

Technical data SKF LGCC 2			
Features	Unit	Value	Standard
Marking	--	K 1/2 G-50	DIN 51825
	--	ISO-L-X-EBIA 1/2	ISO 6743-9
NLGI grade	--	1-2	DIN 51818
Thickener	--	Calcium-12-OH	--
Base oil type	--	Mineral	--
Color	--	Light brown	--
Base oil viscosity	mm ² /s	110 at 40 °C (104 °F)	--
		9 at 100 °C (212 °F)	--
Temperature range	°C (°F)	-50 to 100 (-58 to +212)	-
Drop point	°C (°F)	>135 (275)	DIN ISO 2176
Flow pressure	mbar	<1400 at -50 °C (-58 °F)	DIN 51805/2
Penetration			
-At 60 strokes	mm/10	300-325	DIN ISO 2137
-At 100,000 strokes		+70 max.	
Corrosion protection	--	0-0	ISO 11007
Water resistance	h	3 at 90 °C (194 °F) 1 max.	DIN 51807/1
Copper corrosion	--	1 max.	DIN 51811 / ASTM D4048 / ISO 2160
Performance with extreme pressure (4-ball weld load)	N	Min. 2000	DIN 51350/4

NOTE

The lubricant filling of the pump is determined by the coding in the type identification code (see section 4.9.4).

5 Delivery, returns, storage

5.1 Delivery

After receipt of the shipment, it must be inspected for any shipping damage and for completeness according to the shipping documents. Immediately inform the transport carrier of any shipping damage. The packaging material must be preserved until any discrepancies are resolved.

5.2 Return shipment

Before return shipment, all contaminated parts must be cleaned. If this is not possible or practical, e.g. if it would impede fault detection in the case of complaints, the medium used must always be specified. In the case of products contaminated with hazardous substances as defined by GHS or CLP regulations, the safety data sheet (SDS) must be sent with the product and the packaging must be labelled in accordance with GHS/CLP. There are no restrictions for land, air, or sea transport. The choice of packaging should be based on the specific product and the stresses to be expected during transport (e.g., necessary anti-corrosion measures in the case of shipment by sea). In the case of wooden packaging, the applicable import regulations and the IPPC standards must be observed. Required certificates must be included in the shipping documents. The following information, as a minimum, must be marked on the packaging of return shipments.



Marking of return shipments

5.3 Storage

The following conditions apply to storage:

- Dry, low-dust, vibration-free, in closed rooms
- No corrosive, aggressive substances at the storage location (e.g., UV rays, ozone)
- Protected against animals (insects, rodents)
- If possible, keep in the original product packaging
- Protected from nearby sources of heat or cold
- In the case of large temperature fluctuations or high humidity, take appropriate measures (e.g., heating) to prevent the condensation of water
- Before usage, check products for damage that may have occurred during storage. This applies in particular to parts made of plastic (due to embrittlement).

5.4 Storage temperature range

For parts not filled with lubricant, the permitted storage temperature is the same as the permitted ambient temperature range (see “Technical data”).

5.5 Storage conditions for products filled with lubricant

For products filled with lubricant, the permitted storage temperature range is:

minimum	+ 5 °C	[+41 °F]
maximum	+ 35 °C	[+95 °F]

If the storage temperature range is not maintained, the following steps for replacing the lubricant may not lead to the desired result under certain circumstances.

5.5.1 Storage period up to 6 months

Filled products can be used without implementing additional measures.

5.5.2 Storage period between 6 and 18 months

Pump:

- Connect the pump to a power source
- Switch on the pump and run it until lubricant comes out of every outlet without air bubbles
- Disconnect the pump from the power source
- Remove and dispose of the lubricant that came out

Lines:

- Remove pre-installed lines
- Ensure that both ends of the line are open
- Fill the lines completely with fresh lubricant

Metering devices:

NOTE

Due to the large number of different metering devices, no universally valid statement can be made regarding the removal of the old lubricant and correct bleeding after filling with new lubricant. The instructions can be found in the technical documentation of the specific metering device used.

5.5.3 Storage period more than 18 months

To prevent faults, the manufacturer should be consulted before start-up. The basic procedure for removal of the old lubrication filling corresponds to that for storage periods between 6 and 18 months.

5.6 Declaration of decontamination

If the product came in contact with harmful substances, make sure to thoroughly clean the product before returning it to us. Due to statutory provisions and for the safety of our employees and operation facilities we further need a fully completed and signed “Declaration of decontamination”.

6 Assembly

6.1 General safety instructions

Observe the safety instructions and the technical data in this manual. Additionally, during assembly pay attention to the following:

- Only qualified and authorized technical personnel may install the products described in this manual.
- Adhere to safety distances and legal prescriptions on assembly and prevention of accidents.
- Possibly existing visual monitoring devices, e.g. pressure gauges, MIN/MAX markings, oil inspection glasses must be clearly visible.
- Protect the product against humidity, dust and vibrations.
- Install the product in an easily accessible position. This facilitates other installations, control and maintenance work.

6.2 Transporting the pumps

CAUTION



Injury or pump damage due to improper securing or handling when transporting to the installation location

- During transportation, secure the pump against unintended changes of position, e.g., tilting or falling
- Transport only on marked routes, using suitable transport and lifting gear, including securing straps if necessary.

NOTE

The pumps listed in these instructions may be transported only in a vertically position when filled, because otherwise lubricant could escape from the reservoir and could enter the reservoir ventilation and clog it up.

6.3 Mechanical connection

6.3.1 Minimum mounting dimensions

In order to have sufficient space for maintenance work or for the attachment of additional components for the construction of a centralized lubrication system on the pump, sufficient clearance should be provided for in every direction in addition to the specified dimensions.

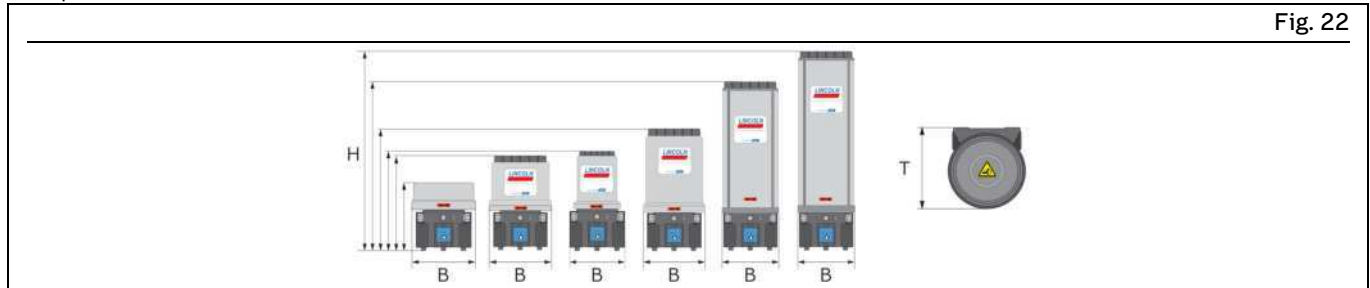

Fig. 22

Table 17

P253 minimum mounting dimensions

Reservoir design	Reservoir size Approx. height (H) mm [in.]							Reservoir size Approx. width (B) mm [in.]							Reservoir size Approx. depth (T) mm [in.]							
	2	4	8	11	15	20	25	2	4	8	11	15	20	25	2	4	8	11	15	20	25	
liters	2	4	8	11	15	20	25	2	4	8	11	15	20	25	2	4	8	11	15	20	25	
	gal.	[0.53]	[1.06]	[2.11]	[2.90]	[3.96]	[5.28]	[6.6]	[0.53]	[1.06]	[2.11]	[2.90]	[3.96]	[5.28]	[6.6]	[0.53]	[1.06]	[2.11]	[2.90]	[3.96]	[5.28]	[6.6]
XN	325	355	458	---	708	---	---	213	230	250	---	240	---	---	224	250	250	---	244	---	---	
	[12.8]	[14]	[18]	---	[27.9]	---	---	[8.39]	[9.06]	[9.84]	---	[9.45]	---	---	[8.81]	[9.84]	[9.84]	---	[9.60]	---	---	
XNFL	244	---	---	---	---	---	---	232	---	---	---	---	---	---	250	---	---	---	---	---	---	
	[9.6]	---	---	---	---	---	---	[9.13]	---	---	---	---	---	---	[9.84]	---	---	---	---	---	---	
XNBO	360	350	457	611	729	---	---	211	232	232	227	216	---	---	224	250	250	224	244	---	---	
	[14.2]	[13.8]	[18]	[24]	[28.7]	---	---	[8.3]	[9.13]	[9.13]	[8.93]	[8.50]	---	---	[8.82]	[9.84]	[9.84]	[8.82]	[9.61]	---	---	
XNBA	---	360	467	---	---	---	---	---	250	230	---	---	---	---	---	250	251	---	---	---	---	
	---	[14.2]	[18.4]	---	---	---	---	---	[9.84]	[9.06]	---	---	---	---	---	[9.84]	[9.88]	---	---	---	---	
XC	330	355	465	---	729	---	---	213	230	230	---	729	---	---	224	250	250	---	250	---	---	
	[13]	[14]	[18.3]	---	[28.7]	---	---	[8.3]	[9.06]	[9.06]	---	[28.7]	---	---	[8.82]	[9.84]	[9.88]	---	[9.88]	---	---	
XCBO	360	355	457	618	730	---	---	213	250	230	220	220	---	---	224	250	251	250	244	---	---	
	[14.2]	[14]	[18]	[24.3]	[28.7]	---	---	[8.3]	[9.84]	[9.06]	[8.66]	[8.66]	---	---	[8.82]	[9.84]	[9.88]	[9.84]	[9.61]	---	---	
XCBA	---	365	467	---	---	---	---	---	250	230	---	---	---	---	---	250	251	---	---	---	---	
	---	[14.4]	[18.4]	---	---	---	---	---	[9.84]	[9.06]	---	---	---	---	---	[9.84]	[9.88]	---	---	---	---	
XBF	---	408	498	611	785	---	---	---	232	251	227	227	---	---	---	250	260	244	244	---	---	
	---	[16]	[19.6]	[24.1]	[30.9]	---	---	---	[9.13]	[9.88]	[8.93]	[8.93]	---	---	---	[9.84]	[10.24]	[9.61]	[9.61]	---	---	
XBD	---	408	457	---	785	967	1150	---	230	230	---	224	224	224	---	250	250	---	247	247	247	
	---	[16.1]	[18]	---	[30.9]	[38.1]	[45.3]	---	[9.06]	[9.06]	---	[8.82]	[8.82]	[8.82]	---	[9.84]	[9.84]	---	[9.72]	[9.72]	[9.72]	
YNBO	360	350	457	---	729	---	---	211	232	232	---	216	---	---	224	250	250	---	244	---	---	
	[14.2]	[13.8]	[18]	---	[28.7]	---	---	[8.3]	[9.13]	[9.13]	---	[8.50]	---	---	[8.82]	[9.84]	[9.84]	---	[9.61]	---	---	
YNBA	---	360	467	---	---	---	---	---	250	230	---	---	---	---	---	250	251	---	---	---	---	
	---	[14.2]	[18.4]	---	---	---	---	---	[9.84]	[9.06]	---	---	---	---	---	[9.84]	[9.88]	---	---	---	---	
YCBO	360	398	510	---	785	---	---	213	230	250	---	227	---	---	224	250	250	---	244	---	---	
	[14.2]	[15.7]	[20.1]	---	[30.9]	---	---	[8.3]	[9.06]	[9.84]	---	[8.93]	---	---	[8.82]	[9.84]	[9.84]	---	[9.61]	---	---	
YCBA	---	---	500	---	---	---	---	---	---	250	---	---	---	---	---	---	250	---	---	---	---	
	---	---	[19.7]	---	---	---	---	---	---	[9.84]	---	---	---	---	---	---	[9.84]	---	---	---	---	

6.3.2 Assembly holes

NOTICE

Damage to the main machine and the pump

The assembly holes should be created only on non-load-bearing parts of the main machine. Do not fasten on two parts which move in opposite directions to one another (e.g., machine base and machine assembly).

When installing pumps with reservoirs of 11 l [2.9 gal.] or greater, the flatness of the upper and lower installation surfaces must not vary by more than 1 mm [0.039 in.] from one another.

The pump housing is fastened at the assembly holes using:

- 2 or 3 screws M8 (8.8)
- 2 or 3 hexagon nuts M8 (8.8)
- 2 or 3 washers (8)

Diameter of the holes:

Ø 9 mm [0.35 in.]

Pumps with 2 l [0.53 gal] reservoir:

The pumps are fastened at the two lower fastening points (Fig. 23/1) or (Fig. 23/2) of the pump housing:

A1 = 162 mm [6.38 in.]

B1 = 180 mm [7.09 in.]

A2 = 124 mm [4.88 in.]

B2 = 112 mm [4.41 in.]

Pumps with 2 l flat reservoir [0.53 gal] or 4 l [1.06 gal], 8 l [2.11 gal], 11 l [2.90 gal], or 15 l [3.96 gal] reservoir:

The pumps are fastened at the three lower fastening points (Fig. 23/1) or (Fig. 23/2) and (Fig. 23/3) of the pump housing:

C1 = 83 mm [3.27 in.]

C2 = 95 mm [3.74 in.]

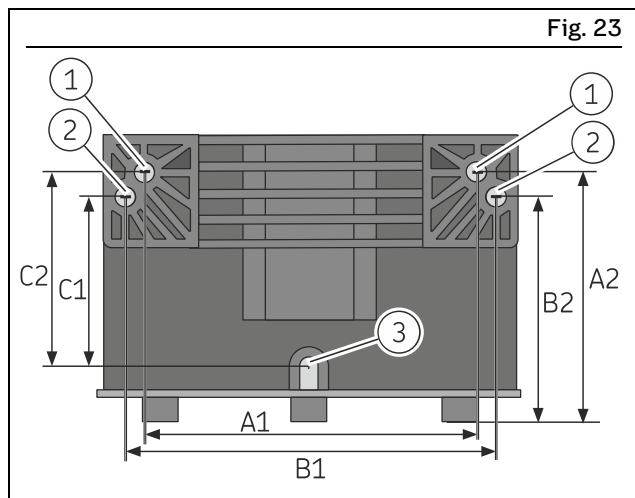

Fastening points at the bottom of the pump housing

Pumps with 11 l [2.90 gal] or 15 l [3.96 gal] reservoir:

The pumps are fastened at the three lower fastening points (Fig. 23/1) or (Fig. 23/2) and (Fig. 23/3) of the pump housing and also at 2 upper assembly points (D):

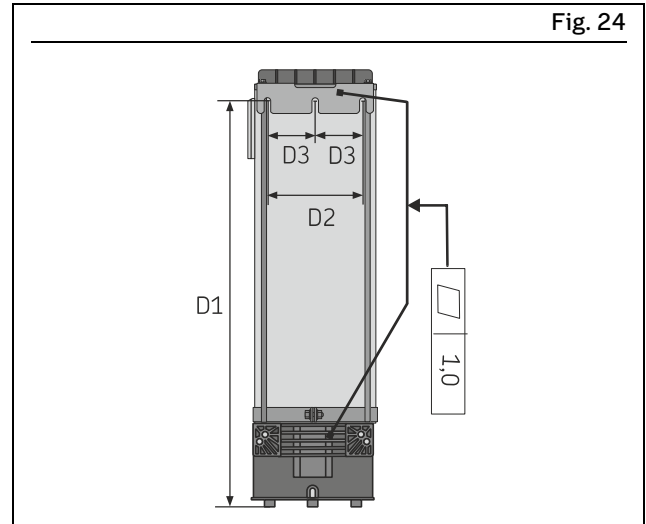

Assembly holes at the top of pumps with 11 l and 15 l reservoirs

The mounting bracket at the top is fastened using:

- 2 screws M8 (8.8)
- 2 hexagon nuts M8 (8.8)
- 2 washers (8)

Tightening torque: 18 Nm ± 1.0 Nm

[13.27 ft.lb. ± 0.74 ft.lb.]

Diameter of the holes on the top mounting bracket:

Ø 9 mm [0.35 in.]

With 11 l [2.90 gal] reservoir:

D1 = 557 mm [21.93 in.]

D2 = 160 mm [6.30 in.]

D3 = 80 mm [3.15 in.]

With 15 l [3.96 gal] reservoir:

D1 = 675 mm [26.57 in.]

D2 = 160 mm [6.30 in.]

D3 = 80 mm [3.15 in.]

6.3.3 Assembly holes for 15 l, 20 l, and 25 l reservoirs

NOTE

The pump is fastened using 2 fastening points at the bottom of the pump housing and 1 fastening plate (15 l) or 2 fastening plates (20 l and 25 l) in the pump's aluminum profile. The fastening plates are included separately with the pump and must be installed by the customer.

Installing the fastening plates:

The fastening plates (Z) are installed in the pump's aluminum profile using the fastening hardware included with the pump.

For each fastening plate:

- 4 x hexagon head screws M8x12 (8.8) A4 DIN EN ISO 4017
- 4 x T-slot nuts M8 A2 10M with spring leaf DIN 508
- 4 x washers A4 8 200 HV

Loctite 274 or equivalent is used to secure the screws.

Tightening torque: 15 Nm ± 1.5 Nm
[11.1 ft.lb. ± 1.1 ft.lb.]

Installing the pump:

The pump must be installed on the main machine using fastening hardware provided by the customer.

For each hole:

- Screw M8 (8.8)
- Hexagon nut M8 (8.8)
- Washers 8 200 HV

Diameter of the holes:
Ø 9 mm [0.35 in.]

Tightening torque: 18 Nm ± 1.0 Nm
[13.27 ft.lb. ± 0.75 ft.lb.]

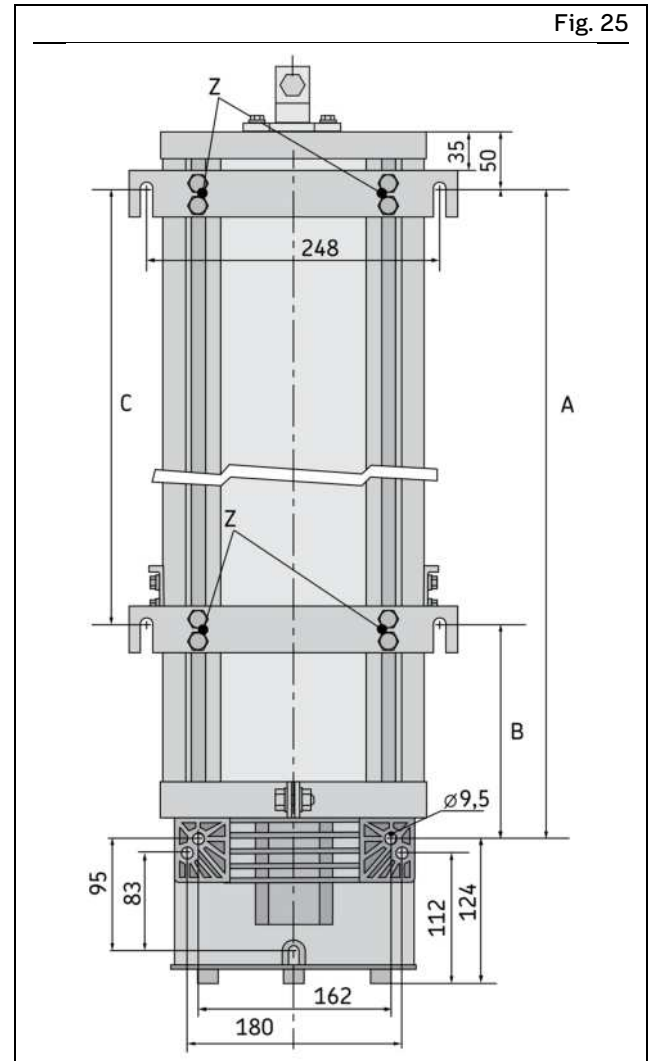

Assembly holes for 15 l, 20 l, and 25 l reservoirs

Table 18

Assembly holes

Reservoir size	A	B	C	Unit
15l	555	---	---	mm
20l	737	367	370	mm
25l	920	455	465	mm

6.4 Electrical connection

⚠ WARNING



Electric shock

Work on electrical components may be performed only by qualified electricians.

At a minimum, the following safety measures must be taken before any work on electrical components is done:



- Isolate, lock and tag out
- Check to ensure the absence of voltage
- Ground and short-circuit the product
- Cover any live parts in the surrounding area

Observe the following instructions for a safe connection:

- The electrical connection must be implemented in accordance with the specifications of the standards of the DIN VDE 0100 series or of the standards of the IEC 60364 series, respectively.
- Connect the electrical lines in such a way that no mechanical forces are transferred to the product.
- The pump must be secured with a suitable external fuse (see terminal diagram).

The electrical connection is established in accordance with the type of connection of the specific pump.

1. Assemble the required cables in accordance with the respective connection diagram or use preassembled cables for the connection.
2. Connect plugs with their respective bushes and secure them against becoming loose using the type of securing method specified for the quick disconnect couplings. Only this way is a safe connection and compliance with the enclosure rating secured.

NOTE

Connect the cables in such a way that no tensile forces can be transferred to the product.

Fig. 26

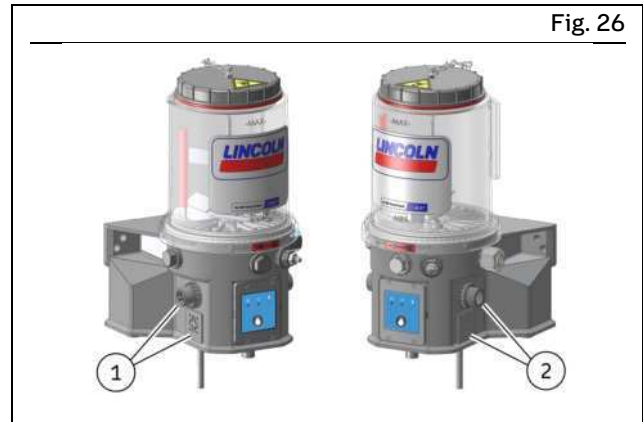

Electrical connection

1. Connectors/cables for the power supply.
2. Connectors/cables for connecting the piston detector and an external control.

NOTE

See also section 15, Overview of cables and possible connections.

6.5 Setting the delivery rate on pump element R

Fig. 27

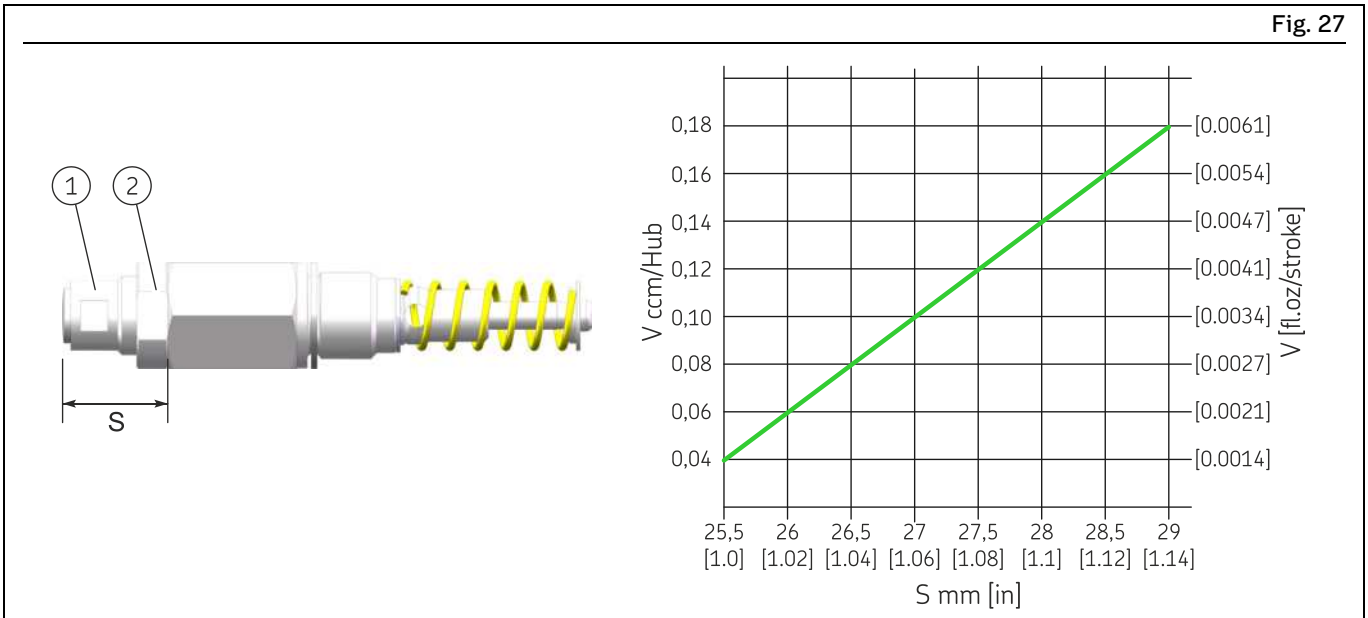

Setting the delivery rate on pump element R

- 1 Spindle
- 2 Locknut

S Spindle setting dimension
V Delivery volume per stroke

NOTE

Be sure to observe the formula for temperature-dependent calculation of the delivery rate using the example of a high-temperature grease, in the section Further information in chapter Influencing factors on the delivery rate on page 17.

NOTE

The delivery rate of pump element R can be adjusted only when the pump is at a standstill.
When delivered, the rate is set to full delivery, meaning the setting dimension is
S = 29 mm [1.14 in.].

Proceed as follows for setting:

1. Release the locknut (Fig. 27/2)
2. Set the delivery rate by turning the spindle (Fig. 27/1) to the dimension specified on the chart in Figure 27.



= lower delivery rate



= higher delivery rate

3. Once the delivery rate is set, tighten the locknut (Fig. 27/1) again.
 - Tightening torque: 20 Nm \pm 2.0 Nm [14.75 ft.lb. \pm 1.4 ft.lb.]

6.6 Installing the pressure limiting valve

Each pump element must be secured with a pressure limiting valve that is suitable for the projected maximum approved operating pressure of the centralized lubrication system.

NOTE

For the 2L XNFL reservoir versions and for all 4L and 8L reservoirs, the adapter 226-14105-5 (see "Spare parts" section) must be screwed in between the pump element and the pressure limiting valve and secured with a medium-strength threadlocker.

Proceed as follows for installation:

1. Remove the plug screw (Fig. 28/2) from the pump element (Fig. 28/1)
2. Screw the pressure limiting valve (Fig. 29/2) into the pump element (Fig. 29/1)
3. Repeat the procedure for each pump element

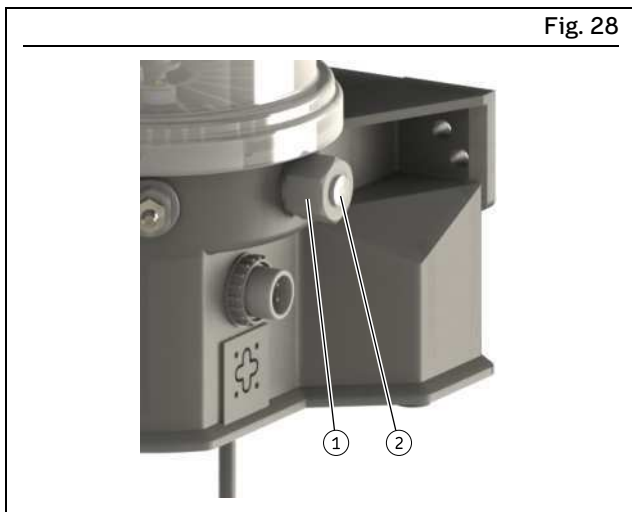

Remove the plug screw



Installing the pressure limiting valve

Tightening torques

- Pressure limiting valve in pump element:
6 Nm - 0.5 Nm [4.43 ft.lb. ± 0.07 ft.lb.]
- Adapter in the pump element:
8 Nm - 0.5 Nm [5.9 ft.lb. ± 0.07 ft.lb.]

Further information in chapter Technical data on page 16

6.7 Connection of the lubrication line

⚠ CAUTION



Risk of slipping

Exercise caution when handling lubricants. Immediately remove and bind any leaked lubricants.

NOTICE

Damage to the higher-level machine caused by faulty planning of the centralized lubrication system

All parts for the construction of the centralized lubrication system must be designed for the maximum operating pressure that occurs, the permissible ambient temperature range, the required delivery volume, and the lubricant to be supplied.

Observe the following assembly information for safe and trouble-free operation:

- Generally valid regulations and company regulations regarding the laying of pressurized pipe and hose lines must be observed.
- Use only clean, pre-filled components and lubrication piping.
- Secure every lubricant line on the pump against excessive pressure through the use of a suitable pressure limiting valve (only in the case of pumps without an internal pressure limiting valve).
- The main lubricant line should be routed on a rising gradient and should be able to be bled at the highest point. Lubrication lines should always be arranged so that air inclusions cannot form anywhere.
- Install lubricant metering devices at the end of the main lubricant line such that the outlets of the lubricant metering devices point upwards wherever possible.
- If the system configuration requires that the lubricant metering devices be arranged below the main lubricant line, they should not be placed at the end of the main lubricant line.
- The flow of lubricant should not be impeded by the presence of sharp bends, angle valves, flap valves, seals protruding inward, or changes in cross-section (large to small). Unavoidable changes in the cross-section in lubrication lines must have smooth transitions.
- Connect the lubricant lines in such a way that no mechanical forces are transferred to the product (stress-free connection).
- Lubrication piping is to be positioned in such a way that they cannot become kinked, pinched or frayed.

6.8 Filling with lubricant

6.8.1 Filling via the reservoir cover

⚠ WARNING



Crushing hazard

Crushing hazard on the rotating stirring paddle. Filling through the opening of the reservoir lid is permitted only when the pump has been disconnected electrically beforehand by detaching the connection (Fig. 30/ 2) from the power supply.

Fig. 30

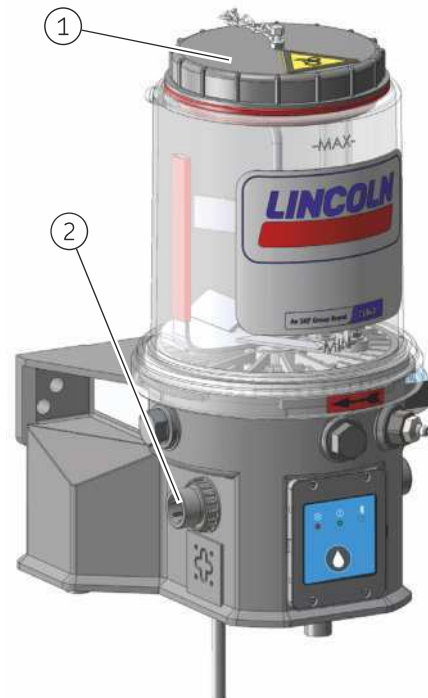

Filling via the reservoir cover

1. Turn the reservoir cover (Fig. 30/1) counterclockwise and detach it from the reservoir. Set the reservoir cover down at a clean location. The inner side of the reservoir cover must not become contaminated. Remove any contaminations which may be present.
2. Fill the reservoir from the top, up to the "MAX" marking. Take care to ensure while doing so that the lubricant is filled in without air inclusions if at all possible.
3. Reinstall the reservoir cover (Fig. 30/1) in clockwise direction.

6.8.2 Filling via filler nipple

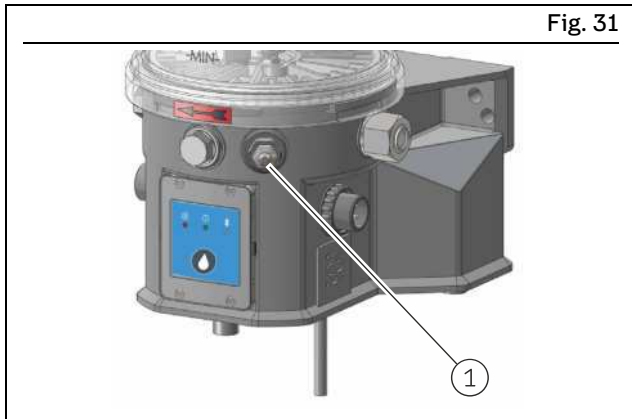

Filling via the filler nipple

1. Connect the fill connection of the filling pump to the filler nipple (Fig. 31/1).
2. Switch on the filling pump and fill the reservoir up to just below the - MAX - marking.
3. Switch off the filling pump and remove it from the filler nipple (Fig. 31/1) of the pump.

6.8.3 Initial filling with double-lip follower plate

NOTE

For initial filling of a pump delivered without lubricant, the pump is fitted with a bleed thread (Fig. 32/1) and a "Read instructions" sticker (Fig. 32/2). The bleed thread ensures that the air under the follower plate can escape when filling the pump for the first time. This prevents faults due to negative effects on the suction characteristics of the pump resulting from air inclusions under the follower plate. The bleed thread (Fig. 32/1) is **ONLY** required for the initial filling and must then be removed together with the "Read instructions" sticker (Fig. 32/2).

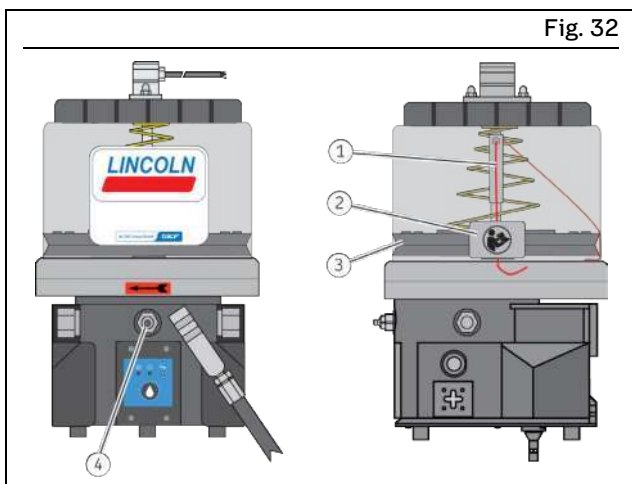

Initial filling

When filling for the first time, proceed as described below:

1. Align the pump so that it is upright.
2. Connect the fill connection of the filling pump to the filler nipple (Fig. 32/4).
3. Switch on the filling pump and carefully fill the space under the double-lip follower plate (Fig. 32/3) completely with lubricant, while observing the follower plate.
4. Switch off the filling pump once all the air under the follower plate has been displaced.
5. Detach the sticker (Fig. 32/2) and slowly and carefully pull the bleed thread (Fig. 32/1) down and out of the pump.
6. Switch on the filling pump and fill the reservoir with lubricant up to just below the - MAX - marking.
7. Properly dispose of the bleed thread and the sticker.

6.9 Initial filling of an empty pump with follower plate

NOTE

For pumps without grease filling, the space underneath the follower plate must be filled with lubricant prior to first start-up. All additional filling is done exclusively via the filler nipple (Fig. 33/5) or the optional fill connection on the pump.

CAUTION



Risk of injury from spring tension

Release the reservoir cover slowly, holding it securely while doing so. Wear goggles.

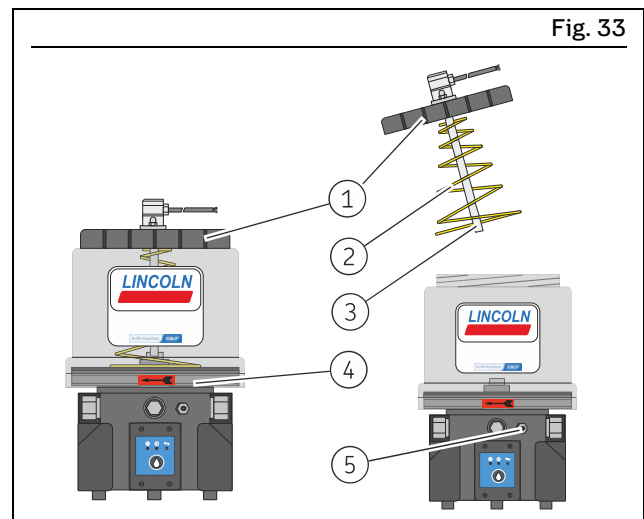

Initial filling of an empty pump with follower plate

1. Turn the reservoir cover (Fig. 33/1) counterclockwise and detach it from the reservoir.
2. Carefully release the spring (Fig. 33/2) from its fixation on the follower plate (Fig. 33/4).
3. Carefully pull the contact rod (Fig. 33/3) out of the follower plate (Fig. 33/4).

4. Remove the reservoir cover, contact rod, and spring together.

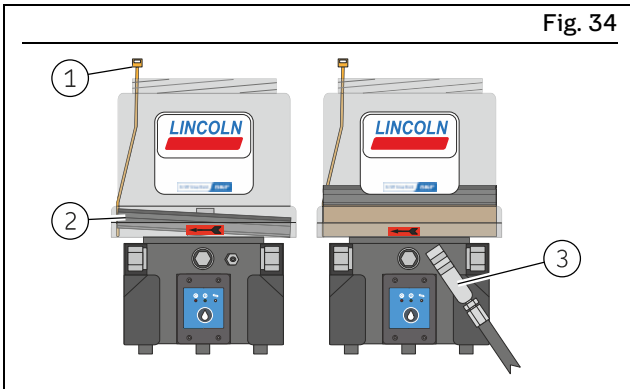

Inserting a cable tie and filling the pump

1. Lightly oil the inner side of the reservoir and the sealing lip of the follower plate.
2. Tilt the follower plate (Fig. 34/2) in the reservoir slightly so that the side opposite the filler nipple (Fig. 33/5) is positioned at the highest point.
3. At this point, push the cable tie (Fig. 34/1) into the area underneath the follower plate as shown.
4. Move the follower plate (Fig. 34/2) back into horizontal position. Take care to ensure while doing so that an air gap is created by the cable tie (Fig. 34/1).
5. Set the fill connection (Fig. 34/3) of the filling pump on the filler nipple and fill the space underneath the follower plate with lubricant. Take care to ensure that no air inclusions remain under the follower plate and that no lubricant reaches the upper side of the follower plate.
6. Remove the cable tie (Fig. 34/1).

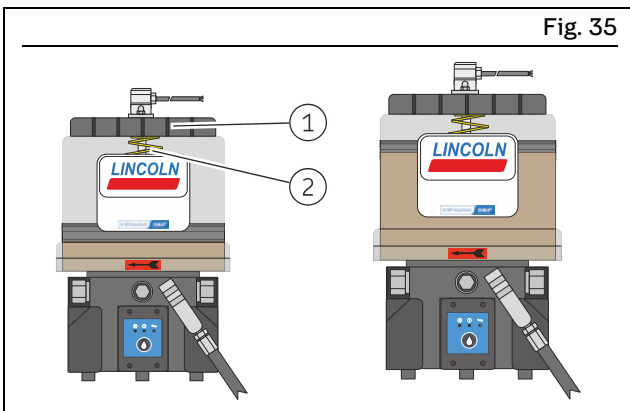

1. Reinstall the spring (Fig. 35/2) and the contact rod.
2. Close the reservoir cover (Fig. 35/1) in clockwise direction.
3. Fill the pump via the filler nipple up to the -MAX- marking.

7 First start-up

In order to warrant safety and function, a person assigned by the operator must carry out the following inspections. Immediately eliminate detected deficiencies. Deficiencies may be remedied by an authorized and qualified specialist only.

7.1 Inspections before first start-up

Table 19		
Checklist: Inspections before first start-up		
Inspections to be performed	YES	NO
Electrical connection established correctly.	<input type="checkbox"/>	<input type="checkbox"/>
Mechanical connection established correctly.	<input type="checkbox"/>	<input type="checkbox"/>
The parameters set on the control are appropriate for the pump's intended application.	<input type="checkbox"/>	<input type="checkbox"/>
The performance characteristics for the aforementioned connections match the specifications in the "Technical data".	<input type="checkbox"/>	<input type="checkbox"/>
All components, e.g. lubrication lines, are pre-filled with the correct lubricating grease and correctly installed.	<input type="checkbox"/>	<input type="checkbox"/>
No apparent damage, contamination, or corrosion.	<input type="checkbox"/>	<input type="checkbox"/>
Product is protected by a suitable pressure relief valve.	<input type="checkbox"/>	<input type="checkbox"/>
Any dismantled protective and monitoring equipment is fully reinstalled and functional.	<input type="checkbox"/>	<input type="checkbox"/>
All warning labels on the product are present and in proper condition.	<input type="checkbox"/>	<input type="checkbox"/>
The lubricant used matches the permissible specifications of the pump and the intended use.	<input type="checkbox"/>	<input type="checkbox"/>

7.2 Inspections during first start-up

Table 20		
Checklist: Inspections during first start-up		
Inspections to be performed	YES	NO
No unusual noises, vibrations, moisture accumulation, or odors present.	<input type="checkbox"/>	<input type="checkbox"/>
No undesired discharge of lubricant at connections (leakage).	<input type="checkbox"/>	<input type="checkbox"/>
Lubricant is fed without bubbles.	<input type="checkbox"/>	<input type="checkbox"/>
The bearings and friction points requiring lubrication receive the planned lubricant volume.	<input type="checkbox"/>	<input type="checkbox"/>

8 Operation

SKF products operate largely automatically.

The activities required during normal operation are limited primarily to inspection of the fill level of pumps without empty signal and to the timely refilling of lubricant.

8.1 Top up lubricant

See the “Filling with lubricant” section.

8.2 Triggering additional lubrication

To trigger an additional lubrication, briefly press the button (Fig. 36/1) on the control panel.



Fig. 36

Triggering additional lubrication

9 Maintenance

Careful and regular maintenance is required in order to detect and remedy possible faults in time. The operator must always determine the specific intervals according to the operating conditions, review them regularly, and adjust them where necessary. If necessary, copy the table for regular maintenance activities.

Table 21

Checklist: Maintenance activities		
Activity to be performed	YES	NO
Mechanical and electrical system connections established correctly	<input type="checkbox"/>	<input type="checkbox"/>
The performance characteristics for the aforementioned connections match the specifications in the "Technical data"	<input type="checkbox"/>	<input type="checkbox"/>
All components such as lubrication lines and metering devices are correctly installed	<input type="checkbox"/>	<input type="checkbox"/>
Product is protected by a suitable pressure limiting valve	<input type="checkbox"/>	<input type="checkbox"/>
No apparent damage, contamination, or corrosion	<input type="checkbox"/>	<input type="checkbox"/>
Any dismantled protective and monitoring equipment is fully reinstalled and functional	<input type="checkbox"/>	<input type="checkbox"/>
All warning labels on the product are present and in proper condition	<input type="checkbox"/>	<input type="checkbox"/>
No unusual noises, vibrations, moisture accumulation, or odors present	<input type="checkbox"/>	<input type="checkbox"/>
No undesired discharge of lubricant (leakages) at connections	<input type="checkbox"/>	<input type="checkbox"/>
Lubricant is fed without bubbles	<input type="checkbox"/>	<input type="checkbox"/>
The bearings and friction points requiring lubrication receive the planned lubricant volume	<input type="checkbox"/>	<input type="checkbox"/>

10 Cleaning

⚠ WARNING

Risk of fatal electric shock





 Cleaning work may only be performed on products that have been de-energized first. When cleaning electrical components, be mindful of the IP enclosure rating.

⚠ WARNING

Serious injury from contact with or inhalation of hazardous substances



   Wear personal protective equipment. Observe the safety data sheet (SDS) of the hazardous substance. Avoid contaminating other objects or the environment during cleaning.

10.1 Basics

Cleaning should be carried out in accordance with the operator's own company rules, and cleaning agents and devices and the personal protective equipment to be used should likewise be selected in accordance with those rules. Only cleaning agents compatible with the materials may be used for cleaning. Completely remove any cleaning agent residue left on the product and rinse with clear water. Unauthorized persons must be kept away. Use signage to indicate wet areas.

10.2 Interior cleaning

The interior normally does not need to be cleaned. The interior of the product must be cleaned if incorrect or contaminated lubricant accidentally enters the product. Please contact our Service department.

10.3 Exterior cleaning

Do not allow any cleaning fluid to enter the interior of the product during cleaning. If products have ultrasonic sensors, the active sensor surface must be cleaned with a cloth when it becomes contaminated.

11 Faults, causes, and remedies

Table 22

Fault table

Fault	Possible cause	Remedy
Pump does not run	<ul style="list-style-type: none"> • Power supply to pump interrupted <ul style="list-style-type: none"> – Main machine is switched off – Pump power cable detached or defective – External fuse defective • The pump is in pause time • The motor of the pump is faulty • Internal cable break 	<ul style="list-style-type: none"> • Check whether one of the specified faults exists, and remedy it according to responsibility • Faults outside one's own scope of responsibility must be reported to the supervisor for initiation of further measures • Please contact our Customer Service if you cannot determine or resolve the error
Pump runs, but supplies either no lubricant at all or not enough	<ul style="list-style-type: none"> • Jam, malfunction within the centralized lubrication system • A check valve in the pump pipe is defective. • Pressure limiting valve defective • Suction bores in the pump pipe are clogged. • Worn pump element • Air inclusion in the lubricant / under the follower plate • Consistency of the lubricant is too high (at low temperatures) • Consistency of the lubricant is too low (at high temperatures) • Metering device within the centralized lubrication system is configured incorrectly 	<ul style="list-style-type: none"> • Check whether one of the specified faults exists, and remedy it according to responsibility • Faults outside one's own scope of responsibility must be reported to the supervisor for initiation of further measures • Please contact our Customer Service if you cannot determine or resolve the error
Pump does not connect via Bluetooth.	<ul style="list-style-type: none"> • SKF eLube app not within range • More than one SKF pump with Bluetooth within range of the SKF eLube app. The SKF eLube app is connected to the wrong pump. 	<ul style="list-style-type: none"> • Reduce the distance to the lubrication pump. If possible, there should be no obstacles between the lubrication pump and the SKF eLube app • Switch the pump off and back on again • Connect the SKF eLube app to the desired pump

12 Repairs

⚠ WARNING



Risk of injury

At a minimum, the following safety measures must be taken before any repairs:



- Unauthorized persons must be kept away
- Mark and secure the work area
- Depressurize the product
- Isolate the product, and lock and tag it out
- Check to ensure live voltage is no longer present
- Ground and short-circuit the product
- Cover any adjacent live parts.

12.1 Replacing pump element and pressure limiting valve

NOTE

The characteristics of the new pump element must match the characteristics of the pump element to be replaced.

Fig. 37



Replacing pump element and pressure limiting valve

Replace the pump element as instructed below:

1. Remove the defective pump element (Fig. 37/1) from the pump housing together with the pressure limiting valve (Fig. 37/2), by unscrewing on the hexagon of the pump element.
2. Screw the new pump element (Fig. 37/1) together with a new packing ring into the pump housing.

NOTE

The torque for tightening the pump element is 20 Nm \pm 2.0 Nm [14.75 ft.lb. \pm 1.4 ft.lb.].

3. Afterwards, screw a new pressure limiting valve (Fig. 37/2) into the pump element.

NOTE

The torque for tightening the pressure limiting valve is 6 Nm -0.5 Nm [4.43 ft.lb. -0.07 ft.lb.].

13 Shutdown, disposal

13.1 Temporary shutdown

Temporary shutdowns should be done by a course of action to be defined by the operator.

13.2 Permanent shutdown, disassembly

Permanent shutdown and disassembly of the product must be planned properly by the operator and conducted in compliance with all applicable laws and regulations.

13.3 Disposal

The waste producer/operator must dispose of the various types of waste in accordance with the applicable laws and regulations of the country in question.

14 Spare parts

Spare parts may be used exclusively for replacement of identical defective parts. Modifications with spare parts on existing products are not allowed.

14.1 Housing cover, complete

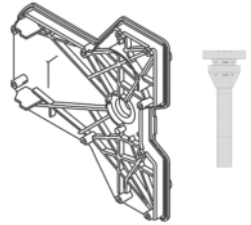
Designation	Pcs.	Item number	Figure
Housing cover, complete	1	544-32217-1	
Housing cover, complete, for UL-certified pumps	1	544-60714-1	

Delivery including dewatering hose and the appropriate number of screws for installation

14.2 Pump elements

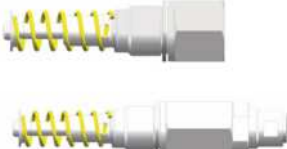
Designation	Pcs.	Item number	Item number	Figure
		C3 design	C5-M design	
Pump element L incl. packing ring	1	600-78018-1	Not available	
Pump element 5 incl. packing ring	1	600-26875-2	600-29303-1	
Pump element 6 incl. packing ring	1	600-26876-2	600-29304-1	
Pump element 7 incl. packing ring	1	600-26877-2	600-29305-1	
Pump element R incl. packing ring	1	655-28716-1	Not available	
Pump element B incl. packing ring	1	600-29185-1	Not available	
Pump element C incl. packing ring	1	600-28750-1	Not available	

14.3 Pressure limiting valves and adapters

Designation	Pcs.	Item number	Figure
SVTS-350-R1/4-D6 C3	1	624-28894-1	
SVTS-350-R1/4-D6 C5 M	1	624-29343-1	
SVET-350-G1/4 A-D8 C3	1	624-29054-1	
SVTS-270-R1/4-1/8 NPTFI-NIP00R-A C3	1	270864	
Adapter S2520 1/4-1/4 PTFE packing ring	1	226-14105-5	

Other pressure limiting valves in C3 and C5-M on request.

14.4 Adapter D6 AX 1/8NPT I C

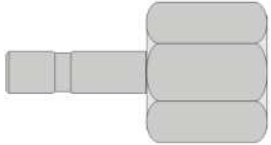
Designation	Pcs.	Item number	Figure
Adapter for pressure limiting valve 270864 C3	1	304-19614-1	

14.5 Motor 12 / 24 V DC

Designation	Pcs.	Item number	Figure
Motor 12 V DC	1	544-85334-1	
Motor 24 V DC	1	544-36913-7	
Delivery includes 1 x motor connection for control circuit board; 2 x O-ring 142 x 4; 3 x O-ring 6 x 2; 1 x radial shaft seal; 3 x self-tapping screw M6 x 25; 3 x washer; 1 x woodruff key; 1 x housing cover with dewatering hose and the matching number of screws for installation			

Table 23

14.6 Adapter with filler nipple





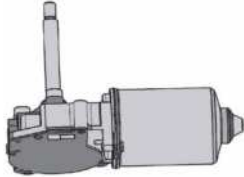

Designation	Pcs.	Item number	Figure
Adapter with filler nipple ST 1/4 acc. to NPTF, incl. seal	1	519-33840-1	
Adapter with filler nipple A2 AR 1/4, incl. seal	1	519-33959-1	
Adapter with filler nipple ST AR 1/4, incl. seal	1	519-33955-1	
Protective cap for filler nipple (red)	1	898-210-050	

Table 24

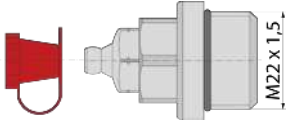
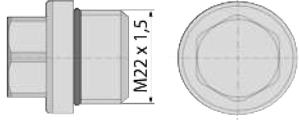
14.7 Closure screw

Designation	Qty.	Part number	Fig.
Cap screw M22x 1.5 including gasket to close unneeded outlets	1	519-60445-1	

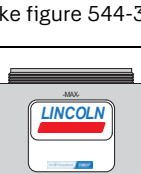
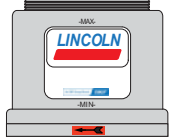
14.8 Transparent reservoir

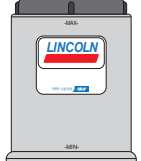
Designation	Pcs.	Item number	Figure
2l XNFL ^{B,C}	1	544-31997-1	
2l XN ^{A,B,C}	1	544-31996-1	
2l XL (with fixed paddle) ^{A,B,C}	1	544-32028-1	
2l XN / YNBO ^{A,B,C,D,E}	1	544-31940-1	
2l XLBO (without stirring paddle) ^{A,B,C,D,E}	1	544-32027-1	(looks like figure 544-31940-1)
4l XNBO / YNBO / XLBO / YLBO / XBF ^{A,B,C}	1	544-31998-1	
4l XN / XL ^{A,B,C,F}	1	544-32695-1	
8l XNBO / YNBO / XLBO / YLBO / XBF ^{A,B,C}	1	544-31999-1	
8l XN / XL ^{A,B,C,F}	1	544-32696-1	

Delivery includes: A = Lincoln/SKF logo, B = rotation arrow, C = O-ring, D = reservoir cover, E = pinch point warning sticker, F = reservoir cover non-detachable (screwed onto the reservoir)

NOTE

Other transparent reservoirs on request.

14.9 Fixed paddle

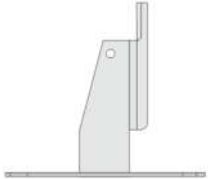
Designation	Pcs.	Item number	Figure
Fixed paddle 4 XNBO	1	444-70490-1	
Fixed paddle 8 XNBO	1	444-70491-1	

14.10 Reservoir cover

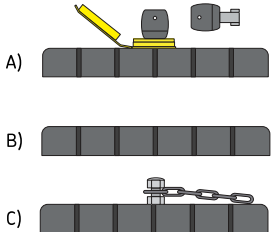
Designation	Pcs.	Item number	Figure
A) Reservoir cover 4/8 l [1.06/2.11 gal.] XNBA/XLBA Lockable, incl. 2 keys and warning sticker	1	544-36963-1	
B) Reservoir cover 4/8 l [1.06/2.11 gal.] Incl. warning sticker	1	544-31992-1	
C) Reservoir cover 2 l [0.53 gal.] XNBO Incl. chain	1	544-85156-1	

15 Appendix

Table 25

Cable colors in accordance with IEC 60757

Abbreviation	Color	Abbreviation	Color	Abbreviation	Color	Abbreviation	Color
BK	Black	GN	Green	WH	White	PK	Pink
BN	Brown	YE	Yellow	OG	Orange	TQ	Turquoise
BU	Blue	RD	Red	VT	Violet	GY	Gray
GNYE	Green/Yellow	RDWH	Red/White	GD	Gold	SR	Silver

Not all cable colors need to be used in the terminal diagrams.

15.1.1 Terminal diagram for full and low-level signals on the reservoir cover

NOTE

The full/low-level signals are connected on the pump housing using a PG9 screwed gland.

Fig. 38

Connection diagram (lubrication grease)
Reed switch for low-level signal

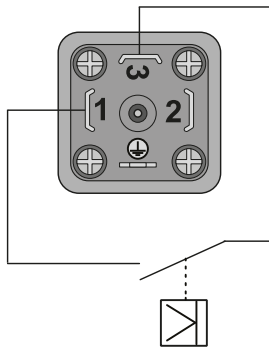

Connection diagram (lubrication grease)
Reed switches for full and low-level signal

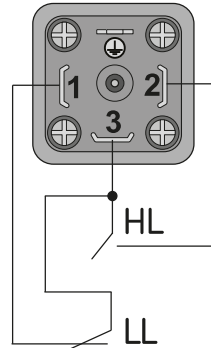

Connection diagram (lubrication oil)
Float switch for low-level signal

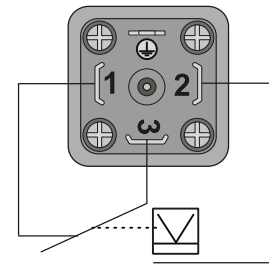

Diagram shows unactuated state, HL = full signal, LL = low-level signal

Terminal diagram of the signal line with rectangular connector on the reservoir cover

Table 26

Electrical data

	Reed switch for low-level signal	Reed switches for full and low-level signal	Float switch for low-level signal
Max. switching capacity	60 VA	60 VA	60 VA
Max. switching voltage	30 V DC	30 V DC	230 V
Max. switched current	700 mA	700 mA	1 A

15.1.2 Overview of cables and possible connections

15.1.2.1 Rectangular and bayonet connectors

Table 27

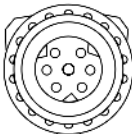
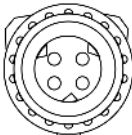
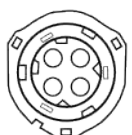
Cables and possible connections for rectangular and bayonet connectors									
External			Pump			Accessories/cables			
Plug	Color	Pin	Color	Internal Function	Polarity	Item number	Length	Cross-section/enclosure rating	
	RD	1	RD	+12/24VDC	+12/24 V	664-85323-5	20 m	4x1 mm ² /	
	BN	2	BN	GND	GND	664-85220-1	12 m	IP 65	
	BK	3	BK	Counter/ignition	Positive	664-36078-7	10 m		
	GN/YE	PE	GY/GY	PE	PE	664-36862-8	6 m		
Rectangular connector / connection type "A" or "F"									
	RD	1	RD	+12/24VDC	+12/24VDC	664-34741-9	20 m	7x1.5 mm ² /	
	BN	2	BN	GND	GND	664-34841-8	15 m	IP 69K	
	BK	3	BK	Counter/ignition	Positive	664-34428-3	10 m		
	WH	4	WH	Add Lub (Z)	Positive (negative)*	664-34841-1	4 m		
	YE	5	YE	NO	dry				
	BU	6	BU	C (max. 30V/4A)	dry				
	GN	7	GN	NC	dry				
Bayonet, 7-pin / connection type "2"									
	BN	1	BN	+12/24VDC	+12/24VDC	6640-00000060	30 m	4x0.5 mm ² /	
	WH	2	WH	KD2 signal	Positive (negative)*	6640-00000058	10 m	IP 69K	
	BU	3	BU	GND	GND	6640-00000062	7 m		
	BK	4	BK	KD1 signal	Positive (negative)*	6640-00000061	3 m		
						6640-00000059	2 m		
Bayonet, 4-pin for one or two piston detectors (KD) Connection types "N" and "M"							6640-00000057	0.4 m	
	RD/YE	1	RD	+12/24VDC	+12/24VDC	664-34167-9	10 m	4x0.5 mm ² /	
	BN/YE	2	BN	GND	GND	664-85279-6	20 m	IP 69K	
	WH/RD	3	WH	Add Lub (Z)	Positive (negative)*				
	WH/BN	4	GN	NC	dry				
Bayonet, 4-pin, power supply / connection type "7"									

* The polarity depends on the pump version (industry standard: positive / vehicle standard: negative)

15.1.2.2 M12 connector

Table 28

Cables and possible connections for M12 connectors

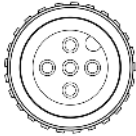
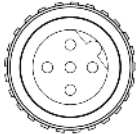
External			Pump			Accessories/cables		
Plug	Color	Pin	Color	Internal Function	Polarity	Item number	Length	Cross-section/enclosure rating
	BN	1	BN	+12/24VDC	+12/24VDC	2370-00000167	5 m	5x0.34 mm ² /
	WH	2	WH	KD2 signal	Positive (negative)*	2370-00000086	3 m	IP 67 ²⁾
	BU	3	BU	GND	GND			
	BK	4	BK	KD1 signal	Positive (negative)*			
	GY	5	--					
								

M12x1, socket A-coded and plug B-coded, for one or two piston detectors (KD) ¹⁾
 Connection type "I" or "K"

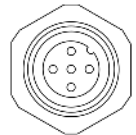
	BN	1	BN	+12/24VDC	+12/24VDC	237-11273-4	10 m	4x0.34 mm ² /
	GR	2	WH	NC (4 A max.)	Positive (negative)*	237-13429-6	5 m	IP 67 ²⁾
	WH	3	BU	Poles	Positive (negative)*	2370-00000114	3 m	
	BK	4	BK	Counter/ignition	Positive			
	BU	5	GY	Add Lub (Z)	Positive (negative)*			

M12x1, A-coded, 5-pin / connection type ???

						179-990-700	--	IP 67 ²⁾
---	--	--	--	--	--	-------------	----	---------------------

M12x1, T connector / connection type "K"

* The polarity depends on the pump version (industry standard: positive / vehicle standard: negative)

¹⁾ Preassembled cable with an M12x1 connector on the piston detector side, 4-pin, A-coded. The connection of two piston detectors requires an additional M12 T connector (item number 179-990-700).

²⁾ To maintain the enclosure rating, the connector must be screwed into the cable socket to 0.6 Nm (IEC 61076- 2).

NOTE

The enclosure rating of the pump depends on its configuration: it is the lowest enclosure rating out of all the components used. To maintain the enclosure rating, observe the various specifications and tightening torques when connecting the pump.

15.1.3 Terminal diagram for P253_x-xxXCxx-xxx-xH-00200000M000-CMxxxx

Table 29

Terminal diagram valid for pumps with the following equipment features

- ✓ Mobile applications
- ✓ 7-pin bayonet connector, (7/7)
- ✓ 12 / 24 VDC
- ✓ 4-pin bayonet connector, (4/3)

Fig. 39

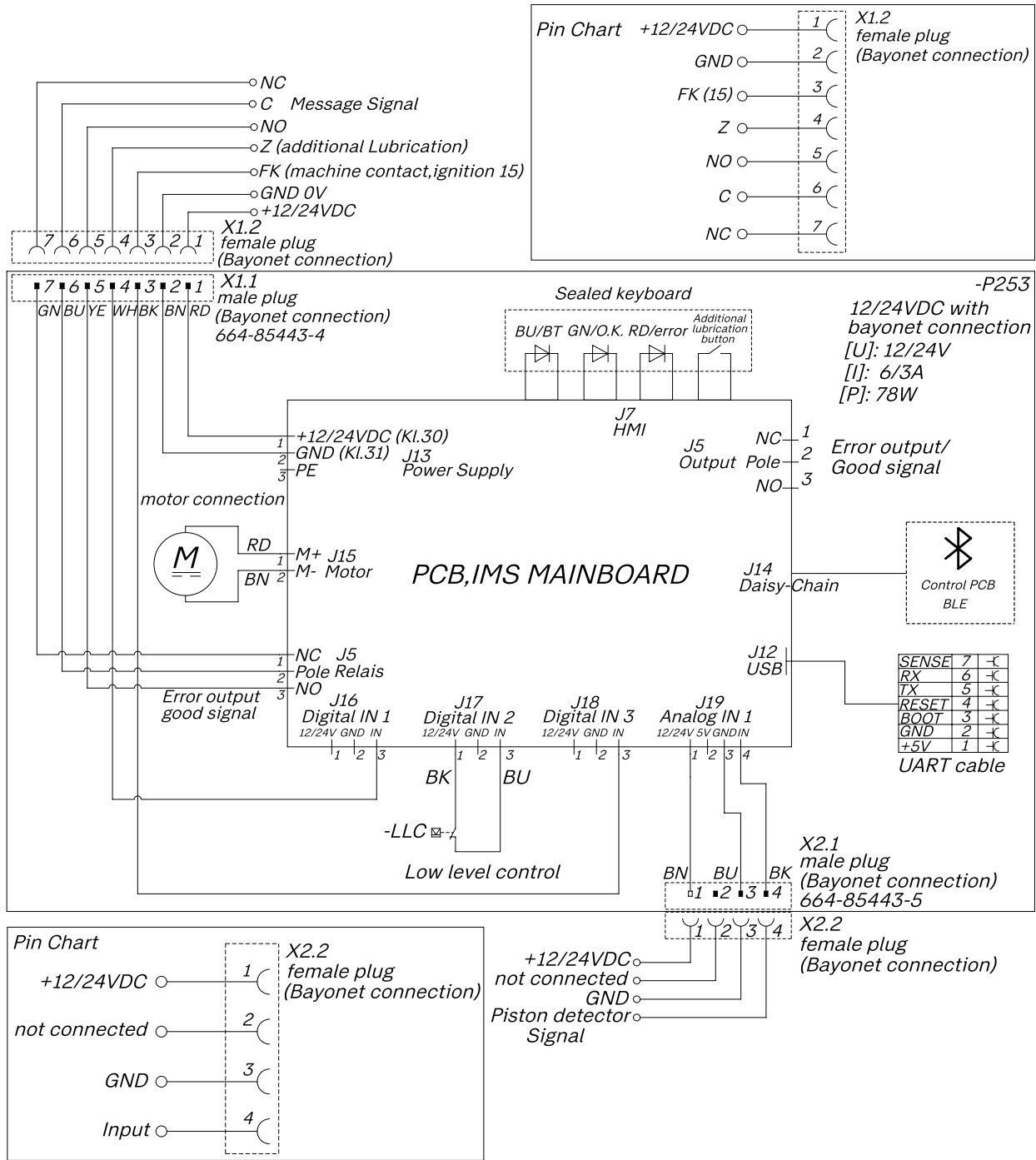

P253 DC Smart with bayonet connector (2x)

15.1.4 Terminal diagram for P253_x-xxXCxx-xxx-xH-A0000000K000-CMxxxx

Table 30

Terminal diagram valid for pumps with the following equipment features

- ✓ Mobile applications
- ✓ Rectangular connector (3+PE)
- ✓ 12 / 24 VDC
- ✓ 5-pin M12x1 socket, B-coded

Fig. 40

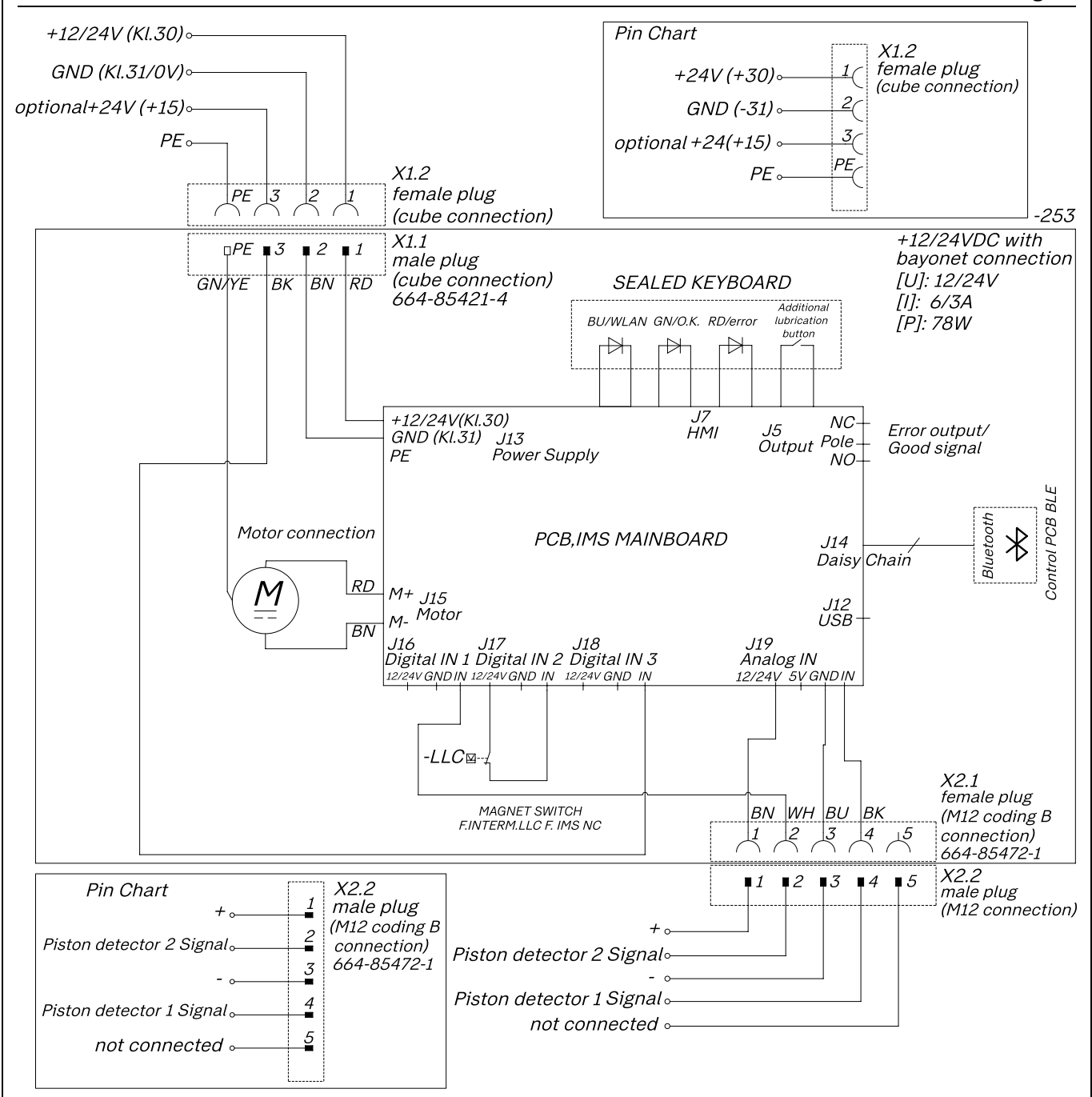

P253 DC Smart with rectangular connector and M12 socket

15.1.5 Terminal diagram for P253_x-xxYCxx-xxx-xH-F0C00000I0Y0-CMxxxx

Table 31

Terminal diagram valid for pumps with the following equipment features

- ✓ Mobile applications
- ✓ Rectangular connector (3+PE)
- ✓ 5-pin M12x1 socket, B-coded
- ✓ 12 / 24 VDC
- ✓ 5-pin M12x1 socket, A-coded
- ✓ PG 9 + rectangular connector (low-level signal)

Fig. 41

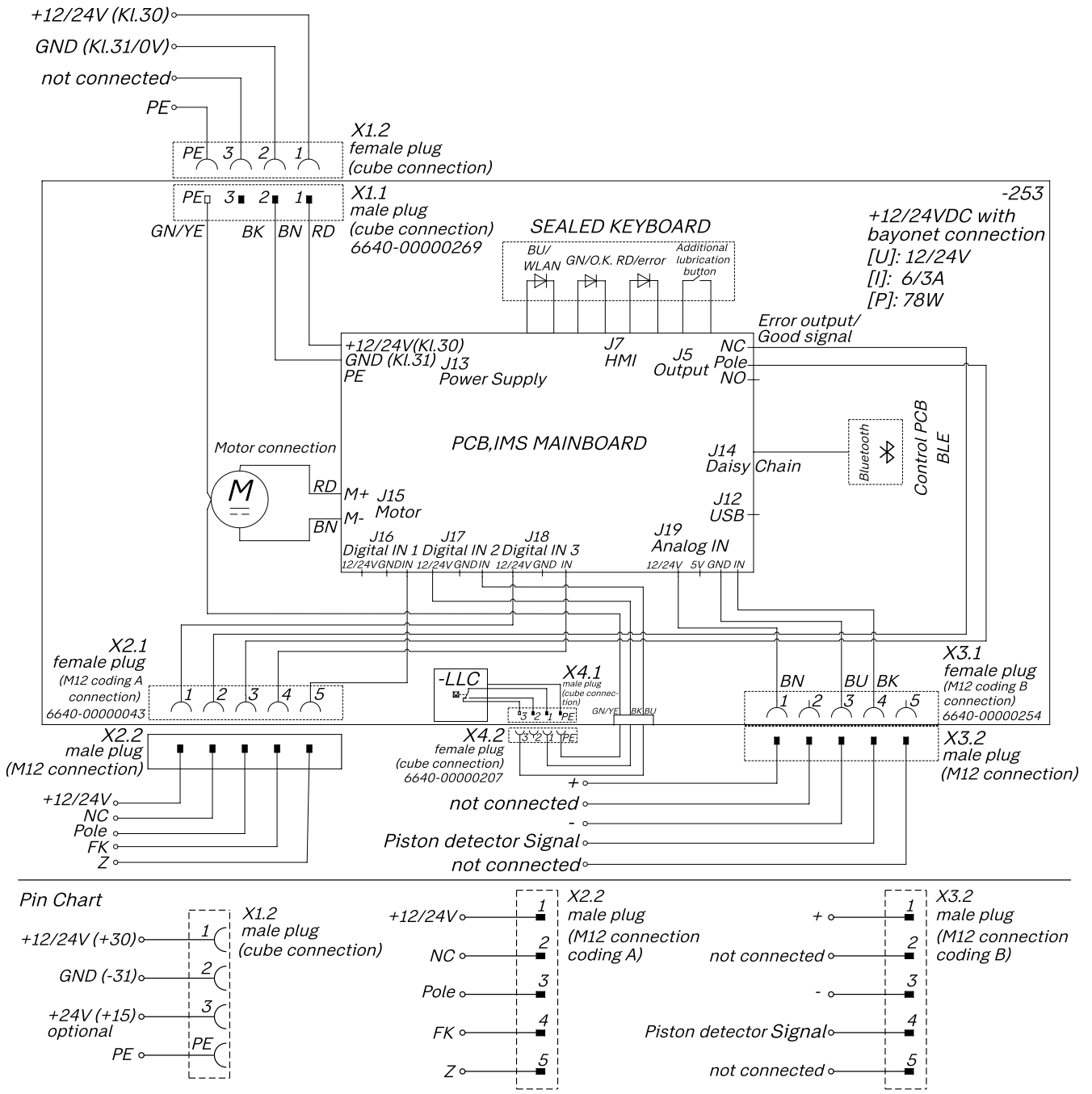

P253 DC Smart with rectangular connector and M12 socket (2x)

15.1.6 Terminal diagram for P253_x-xxXCxx-xxx-xH-00700000M000-CMxxxx

Table 32

Terminal diagram valid for pumps with the following equipment features

- ✓ Mobile applications
- ✓ 12 / 24 VDC
- ✓ 4-pin bayonet connector, (4/4)
- ✓ 4-pin bayonet connector, (4/3)

Fig. 42

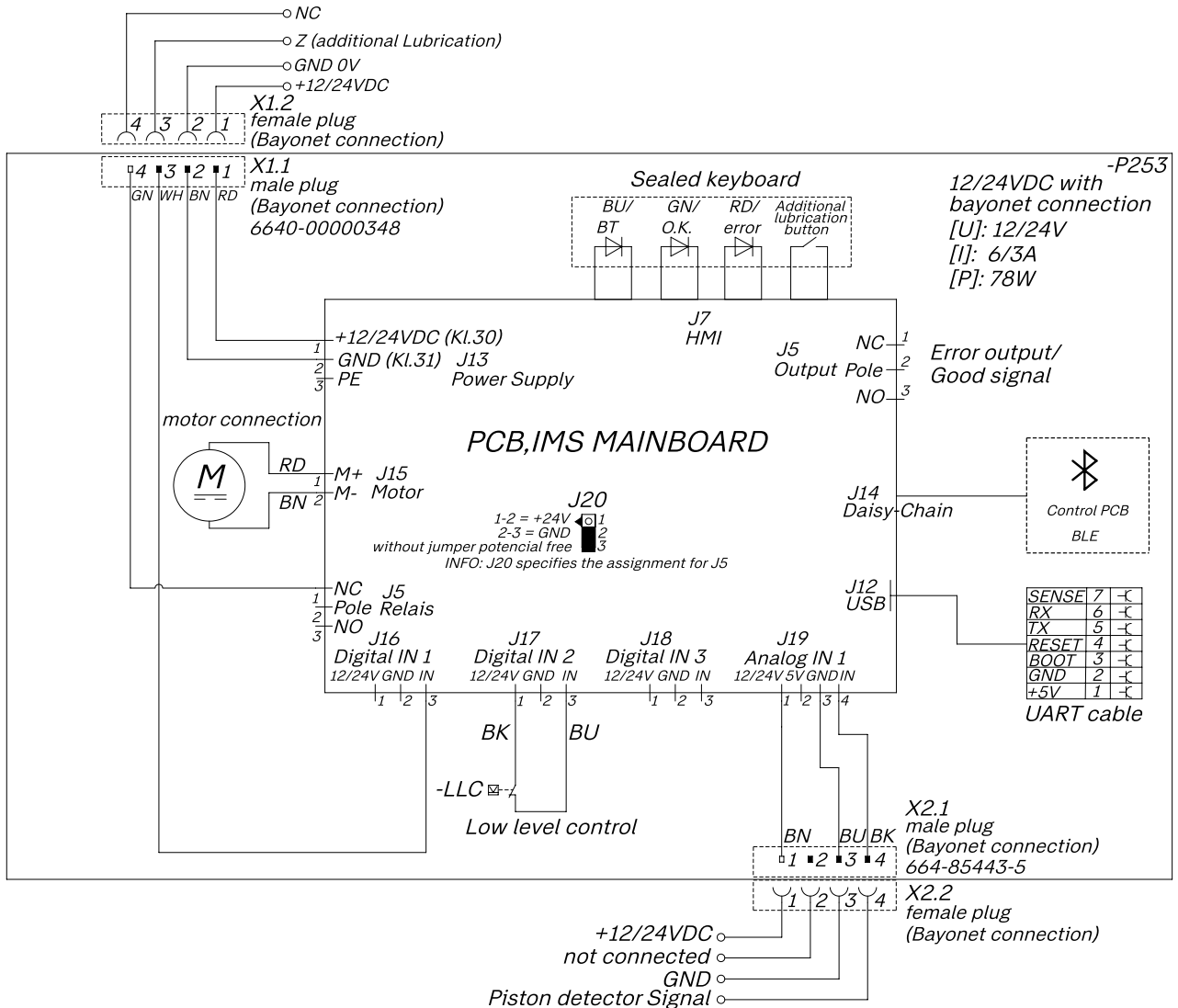

Pin Chart

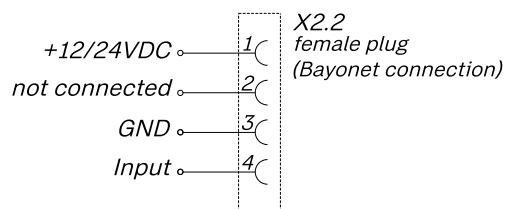
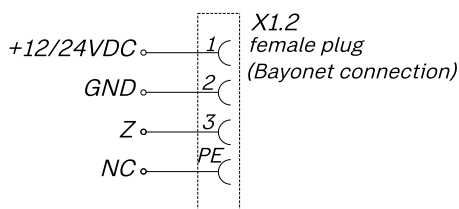

P253 DC Smart with bayonet connector (2x)

部件名称 (Part Name)	有毒害物质或元素 (Hazardous substances)				
	铅	汞	镉	六价铬	多溴联苯
	Lead (Pb)	Mercury (Hg)	Cadmium (Cd)	Hexavalent Chromium (Cr(VI))	Polybrominated biphenyls (PBB)
用钢和黄铜加工的零件 (Components made of machining steel and brass)	X	0	0	0	0
部件名称 (Part Name)	多溴二苯醚	邻苯二甲酸二丁酯	邻苯二甲酸丁苄酯	邻苯二甲酸二(2-乙 基己基)酯	邻苯二甲酸二异 丁酯
	Polybrominated diphenyl ethers (PBDE)	Dibutyl phthalate (DBP)	Benzyl butyl phthalate (BBP)	Bis (2-ethylhexyl) phthalate (DEHP)	Diisobutyl phthalate (DIBP)
用钢和黄铜加工的零件 (Components made of machining steel and brass)	0	0	0	0	0

本表格依据SJ/T11364的规定编制

(This table is prepared in accordance with the provisions of SJ/T 11364.)

0:	表示该有毒有害物质在该部件所有均质材料中的含量均在GB/T 26572 规定的限量要求以下。 (Indicates that said hazardous substance contained in all of the homogeneous materials for this part is below the limit requirement of GB/T 26572.)
X:	表示该有毒有害物质至少在该部件的某一均质材料中的含量超出GB/T 26572标准规定的限量要求。 (Indicates that said hazardous substance contained in at least one of the homogeneous materials used for this part is above the limit requirement of GB/T 26572.)

skf.com/lubrication

® SKF is a registered trademark of the SKF Group.

™ eLube is a trademark of the SKF Group.

© SKF Group 2025

Reprint or reproduction of the contents of this information - even in part - is permitted only with SKF's prior written consent.

951-171-056-EN 27.11.2025