

Piston pump P502

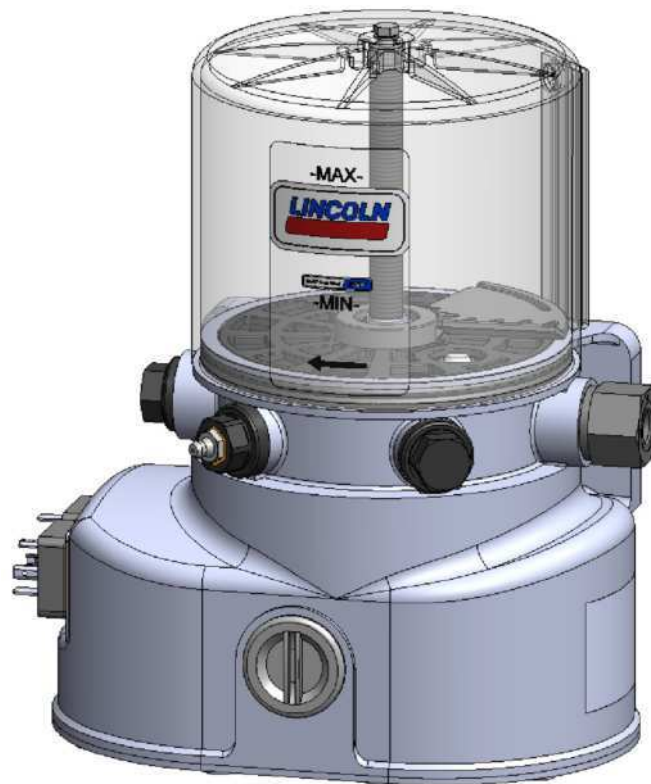

Created on: **22.01.2026**

Document no.: **951-171-009-EN**

Version: **18**



Read these instructions before installation or start-up of the product and keep them readily available for later consultation!

Original EC Declaration of Incorporation in accordance with Directive 2006/42/EC, Appendix II Part 1 B

The manufacturer hereby declares at its sole responsibility that the partly completed machinery conforms to the essential health and safety requirements of the Machinery Directive 2006/42/EC, Annex I, marked in the Annex to the EC Declaration of Incorporation as applicable and fulfilled at the time of placing on the market.

The special technical documents were prepared following Annex VII part B. Upon justifiable request, these special technical documents can be forwarded electronically to the respective national authorities. The authorized company for the compilation of the technical documentation is the manufacturer.

Designation: Electrically operated pump for the feeding of lubricants in interval operation inside a centralized lubrication system
Type: P502
Item number: 658-* | 6580-*

Furthermore, the following directives and standards were applied in the respective applicable areas:

2006/42/EC: Machinery Directive

2011/65/EU: RoHS II

2014/30/EU: Electromagnetic Compatibility

EN ISO 12100:2010 EN 60204-1:2018 EN 61000-6-2:2005/AC:2005 EN 61000-6-4:2007/A1:2011

EN 61131-2:2007 EN 809:1998+A1:2009/AC:2010 EN 60034-1:2010/AC:2010 EN 60947-5-1:2017

EN IEC 60947-5-2:2020

EN IEC 63000:2018

The partly completed machinery must not be put into service until it has been established that the machinery into which it is to be incorporated is in compliance with the provisions of the Machinery Directive 2006/42/EC and all other applicable Directives.

Walldorf, 22.01.2026

Wilhelm Burger

COO Managing Director

SKF Lubrication Systems

Germany GmbH

Manufacturer: SKF Lubrication Systems Germany GmbH, Heinrich-Hertz-Str. 2-8, 69190 Walldorf, Germany

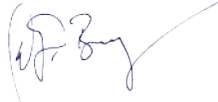

Original UK Declaration of incorporation according to the Supply of Machinery (Safety) Regulations 2008 No. 1597 Annex II

The manufacturer hereby declares under sole responsibility that the partly completed machinery complies with the essential health and safety requirements of UK legislation Supply of Machinery (Safety) Regulations 2008 No. 1597 Annex I, marked in the Annex to the EC Declaration of Incorporation as applicable and fulfilled at the time of placing on the market.

The special technical documents were prepared following Annex VII part B. Upon justifiable request, these special technical documents can be forwarded electronically to the respective national authorities. The authorized company for the compilation of the technical documentation is SKF (U.K.) Limited, 2 Canada Close, Banbury, Oxfordshire, OX16 2RT, GBR.

Designation: Electrically operated pump for the feeding of lubricants in interval operation inside a centralized lubrication system
Type: P502
Item number: 658-* | 6580-*

Furthermore, the following regulations and standards were applied in the respective applicable areas:

Supply of Machinery (Safety) Regulations 2008 No. 1597

Electromagnetic Compatibility Ordinance 2016 No. 1091

The Restriction of the Use of Certain Hazardous Substances in Electrical and Electronic Equipment Regulations 2012 No. 3032

EN ISO 12100:2010 EN 60204-1:2018 EN 61000-6-2:2005/AC:2005 EN 61000-6-4:2007/A1:2011

EN 61131-2:2007 EN 809:1998+A1:2009/AC:2010 EN 60034-1:2010/AC:2010 EN 60947-5-1:2017

EN IEC 60947-5-2:2020

EN IEC 63000:2018

The partly completed machinery must not be put into service until it has been established that the machinery into which it is to be incorporated is in compliance with the provisions of UK legislation Supply of Machinery (Safety) Regulations 2008 No. 1597 and all other applicable Directives.

Walldorf, 22.01.2026

Wilhelm Burger

COO Managing Director

SKF Lubrication Systems

Germany GmbH

Manufacturer: SKF Lubrication Systems Germany GmbH, Heinrich-Hertz-Str. 2-8, 69190 Walldorf, Germany



Appendix to Declaration of Incorporation in accordance with 2006/42/EC, Annex II, No. 1 B

Description of the essential health and safety requirements according to 2006/42/EC, Annex I, which have been applied and fulfilled. Any essential health and safety requirements not listed here are not relevant to this product.

Table 1

**Appendix to Declaration of Incorporation
Valid for: P502 lubricant feed pumps**

No.:	Essential health and safety requirement	Applicable:	Fulfilled:
1.1.1	Definitions	Yes	Yes
1.1.2	Principles of safety integration	Yes	Yes
1.1.3	Materials and products	Yes	Partially ¹⁾
1.1.5	Design of machinery to facilitate its handling	Yes	Yes
1.1.6	Ergonomics	Yes	Partially ²⁾
1.2	Control systems	Yes	Yes
1.2.1	Safety and reliability of control systems	Yes	Yes
1.2.3	Starting	Yes	Yes
1.2.6	Failure of the power supply	Yes	Yes
1.3	Protection against mechanical hazards	Yes	Yes
1.3.1	Risk of loss of stability	Yes	Yes
1.3.2	Risk of break-up during operation	Yes	Partially ³⁾
1.3.4	Risks due to surfaces, edges or angles	Yes	Yes
1.3.7	Risks related to moving parts	Yes	Yes
1.3.9	Risks of uncontrolled movements	Yes	Yes
1.5	Risks due to other hazards	Yes	Yes
1.5.1	Electricity supply	Yes	Yes
1.5.6	Fire	Yes	Yes
1.5.8	Noise	Yes	Yes
1.5.11	External radiation	Yes	Yes
1.5.13	Emissions of hazardous materials and substances	Yes	Yes
1.5.15	Risk of slipping, tripping, or falling	Yes	Yes
1.6	Servicing		
1.6.1	Machinery maintenance	Yes	Yes
1.6.2	Access to operating positions and servicing points	Yes	Partially ⁴⁾
1.6.4	Operator interventions	Yes	Yes
1.7	Information	Yes	Yes
1.7.1	Information and warnings on the machinery	Yes	Yes
1.7.1.1	Information and information devices	Yes	Yes
1.7.2	Warning of residual risks	Yes	Yes
1.7.3	Marking of machinery	Yes	Yes
1.7.4	Operating instructions/assembly instructions	Yes	Yes
1.7.4.1	General principles for the drafting of operating instructions/assembly instructions	Yes	Yes
1.7.4.2	Contents of the operating instructions/assembly instructions	Yes	Yes
1.7.4.3	Sales literature	Yes	Yes

- 1) Not completely fulfilled: Hazards due to the lubricant used must be assessed by the operator on the basis of the Safety Data Sheet (SDS) and, if necessary, protective measures must be taken.
- 2) Not completely fulfilled: The operator must ensure that the pump is integrated into the higher-level machine in such a way that the pump can be operated and filled ergonomically.
- 3) Not completely fulfilled: The operator must protect the lubrication system against excessive pressure. For this purpose, a pressure limiting valve with max. 270 bar opening pressure must be provided on each pump element.
- 4) Not completely fulfilled: The operator must ensure that the pump is integrated into the higher-level machine in such a way that the pump can be operated without danger.

Masthead

Manufacturer

SKF Lubrication Systems Germany GmbH
Email: Lubrication-germany@skf.com
www.skf.com/lubrication

Berlin Plant
Motzener Strasse 35/37
12277 Berlin
Germany
Tel. +49 (0)30 72002-0
Fax +49 (0)30 72002-111

Walldorf Plant
Heinrich-Hertz-Strasse 2-8
69190 Walldorf, Germany
Germany
Tel.: +49 (0) 6227 33-0
Fax: +49 (0) 6227 33-259

Authorized local distributors

- Great Britain -
SKF (U.K.) Limited,
2 Canada Close, Banbury, Oxfordshire,
OX16 2RT, GBR.

- North America -
SKF Lubrication Business Unit
Lincoln Industrial
5148 North Hanley Road, St. Louis,
MO. 63134 USA

- South America -
SKF Argentina Pte. Roca 4145,
CP 2001 Rosario, Santa Fe

Warranty

The instructions contain no statements regarding the warranty or liability for defects. That information can be found in our General Terms of Payment and Delivery.

Training

We conduct detailed training in order to enable maximum safety and efficiency. We recommend taking advantage of this training. For further information, contact your authorized SKF dealer or the manufacturer.

Table of contents

Masthead	4
Table of contents	5
Safety alerts, visual presentation, and layout	7
1 Safety instructions.....	8
1.1 General safety instructions.....	8
1.2 General electrical safety instructions	8
1.3 General behaviour when handling the product	8
1.4 Intended use	8
1.5 Persons authorized to use the product.....	8
1.6 Foreseeable misuse	9
1.7 Referenced documents.....	9
1.8 Prohibition of certain activities	9
1.9 Painting plastic components and seals.....	9
1.10 Safety markings on the product	9
1.11 Note on the type plate.....	9
1.12 Notes on CE marking	9
1.13 Note on Low Voltage Directive	9
1.14 Note on Pressure Equipment Directive.....	10
1.15 Note on UKCA marking	10
1.16 Note on UL mark.....	10
1.17 Note on ECE mark	10
1.18 Note on EAC marking.....	10
1.19 Note on China RoHS mark	10
1.20 Emergency shutdown	10
1.21 First start-up, daily start-up	10
1.22 Residual risks.....	11
2 Lubricants.....	13
2.1 General information	13
2.2 Material compatibility.....	13
2.3 Temperature properties	13
2.4 Aging of lubricants.....	13
2.5 Avoidance of faults and hazards	13
2.6 Solid lubricants	13
2.7 Chisel pastes	13
3 Overview, functional description.....	14
3.1 Described versions.....	14
3.1.1 P502 with follower plate.....	14
3.1.2 P502 without follower plate	14
3.2 Overview/functional description.....	14
4 Technical data	18
4.1 Factory settings of the lubrication and pause times for pumps with control circuit board.....	19
4.2 Required values of the lubrication and pause times for pumps without control circuit board	19
4.3 Possible settings of the lubrication and pause times for pumps with control circuit board.....	19
4.4 Tightening torques.....	20
4.5 Lubricant requirement when an empty pump is filled for the first time.....	20
4.6 Usable reservoir volume	20
5 Delivery, returns, storage	23
5.1 Delivery	23
5.2 Return shipment	23
5.3 Storage.....	23
5.4 Storage temperature range.....	23
5.5 Storage conditions for products filled with lubricant	23
5.5.1 Storage period up to 6 months.....	23
5.5.2 Storage period between 6 and 18 months.....	23
5.5.3 Storage period more than 18 months	23
5.6 Declaration of decontamination.....	23
6 Assembly.....	24
6.1 Mounting dimensions	24
6.2 Assembly holes.....	24
6.3 Installing the pump element.....	24
6.4 Setting the delivery rate on pump element R or KR	25
6.5 Installing the pressure limiting valve	25
6.6 Installing the centralized lubrication system.....	26
6.7 Connection of the lubrication line.....	27
6.8 Electrical connection	27
6.9 Initial filling with a follower plate	28
6.9.1 Filling via filler nipple	28
6.9.2 Filling via fill connection	30
6.10 Initial filling without a follower plate.....	31
6.10.1 Filling via filler nipple	31
6.10.2 Filling via fill connection	31
6.11 Setting the lubrication time and pause time	31
6.11.1 Pumps without a control circuit board.....	31
6.11.2 Pumps with a control circuit board.....	31
6.12 Jumper settings	32
7 First start-up	33
7.1 General	33
7.2 Inspection before initial start-up	33
7.3 Inspections before first start-up	33
7.4 Inspections during first start-up.....	33
7.5 Triggering additional lubrication.....	34
8 Operation	35
8.1 Operation	35
8.2 Filling the reservoir during operation.....	35
8.2.1 Filling via filler nipple.....	35
8.2.2 Filling via fill connection	35
9 Maintenance	36
10 Cleaning.....	37
10.1 Basics	37
10.2 Interior cleaning.....	37
10.3 Exterior cleaning.....	37
11 Faults, causes, and remedies.....	38
11.1 Fault tables	38
11.2 Display of fault codes.....	39
12 Repairs	41
12.1 Replacing the control circuit board.....	41
12.2 Checks after replacing the control circuit board..	42
12.2.1 Visual inspection	42
12.2.2 Electrical safety check.....	42
12.2.3 Electrical functional test.....	42
12.2.4 Archiving	42
12.3 Replacing the pressure limiting valves and pump elements.....	43
12.5 Replacing a reservoir with a follower plate.....	44
12.6 Replacing the follower plate.....	45
12.7 Replacing a reservoir without a follower plate	46
13 Shutdown, disposal.....	47
13.1 Temporary shutdown.....	47
13.2 Permanent shutdown, disassembly.....	47
13.3 Disposal	47
14 Spare parts	48
14.1 Pump elements	48

14.2 Pressure limiting valve	48
14.3 Adapter with lubricant nipple.....	48
14.4 Spare part kit for replacing the reservoir	48
14.5 Spare part kit for replacing the follower plate.....	49
14.6 Spare part kit for replacing the control circuit board.....	49
14.7 Spare part kit for replacing the screw cap.....	49
15 Appendix.....	50
15.1 Cable colors in accordance with IEC 60757.....	50
15.1.1 Recommended contact protection for switching inductive loads	50
15.1.2 Wire assignment of the connector plugs.....	50
15.2 Assignment of the terminal diagrams to the pump	52
15.3 Terminal diagram 12 /24 V DC with bayonet connector and control circuit board V20	53
15.4 Terminal diagram 12 /24 V DC with bayonet connector and control circuit board V10.....	54
15.5 Terminal diagram 12 /24 V DC with rectangular connector and control circuit board V20	55
15.6 Terminal diagram 12 /24 V DC with rectangular connector and control circuit board V10.....	56
15.7 Terminal diagram 24 V DC with M12 connector and control circuit board V20	57
15.8 Terminal diagram 24 V DC with M12 connector without control circuit board	58
15.9 Terminal diagram 12 /24 V DC with rectangular connector without control circuit board.....	59
15.10 Terminal diagram 12 /24 V DC with bayonet connector without control circuit board.....	60
15.11 Terminal diagram 12 /24 V DC with bayonet connector without control circuit board and without low-level signal.....	61
15.12 Terminal diagram 12 /24 V DC with rectangular connector without control circuit board and without low-level signal.....	62
15.13 Terminal diagram 24 V DC with M12 connector and control circuit board.....	63
15.14 China RoHS Table.....	64

Safety alerts, visual presentation, and layout

While reading these instructions, you will encounter various symbols, illustrations, and text layouts intended to help you navigate and understand the instructions. Their meaning is explained below.

Safety alerts:

Activities that present specific hazards (to life and limb or possible damage to property) are indicated by safety alerts. Always be sure to follow the instructions given in the safety alerts.

DANGER

These safety alerts indicate an imminent danger. Ignoring them will result in death or serious injury

WARNING

These safety alerts indicate potentially imminent danger. Ignoring them could result in death or serious injury

CAUTION

These safety alerts indicate potentially imminent danger. Ignoring them could result in minor injury

NOTICE

These safety alerts indicate a potentially harmful situation. Ignoring them could result in damage to property or malfunctions

Illustrations:

The illustrations used depict a specific product. For other products, they may have the function of a diagram only. This does not alter the basic workings and operation of the product.

Text layout:

- **First-order bulleted lists:** Items on a bulleted list start with a solid black dot and an indent.
 - **Second-order bulleted lists:** If there is a further listing of subitems, the second-order bulleted list is used.
- 1 **Legend:** A legend explains the numbered contents of an illustration, presented as a numbered list. Items in a legend start with a number (with no dot) and an indent.
 - **Second-order legend:** In some cases, the numbered contents of an image represent more than just one object. A second-order legend is then used.
- 1. **Instruction steps:** These indicate a chronological sequence of instruction steps. The numbers of the steps are in bold and are followed by a period. If a new activity follows, the numbering starts again at “1.”
 - **Second-order instruction steps:** In some cases, it is necessary to divide up a step into a few substeps. A sequence of second-order instruction steps is then used.

1 Safety instructions

1.1 General safety instructions

- Putting the products into operation or operating them without having read the instructions is prohibited. The operator must ensure that the instructions are read and understood by all persons tasked with working on the product or who supervise or instruct such persons. Retain the instructions for further use.
- The product may only be used in awareness of the potential dangers, in proper technical condition, and according to the information in this manual.
- Any faults that could affect safety must be remedied according to responsibility. The supervisor must be notified immediately in case of malfunctions outside one's individual scope of responsibility.
- Unauthorized modifications and changes can have an unpredictable effect on safety and operation. Unauthorized modifications and changes are therefore prohibited. Only original SKF spare parts and SKF accessories may be used.
- Any unclear points regarding proper condition or correct assembly/operation must be clarified. Operation is prohibited until issues have been clarified.
- The components used must be suitable for the intended use and the applicable operating conditions, e.g. max. operating pressure and ambient temperature range, and must not be subjected to torsion, shear, or bending.

1.2 General electrical safety instructions

- Electrical devices must be kept in proper condition. This must be ensured by periodic inspections in accordance with the relevant applicable standards and technical rules. The type, frequency, and scope of the inspections must be determined in accordance with the risk assessment to be carried out by the operator. Work on electrical components may be performed only by qualified electricians. Connect the electrical power only in accordance with the valid terminal diagram and in observance of the relevant regulations and the local electrical supply conditions.
- Work on electrical components may be performed only in a voltage-free state and using tools suitable for electrical work. Do not touch cables or electrical components with wet or moist hands.
- Fuses must not be bridged. Always replace defective fuses with fuses of the same type.
- Ensure proper connection of the protective conductor for products with protection class I. Observe the specified enclosure rating.
- The operator must implement appropriate measures to protect vulnerable electrical devices from the effects of lightning during use. The electrical device is not furnished with a grounding system for the dissipation of the respective electric charge and does not have the voltage strength necessary to withstand the effects of lightning.

1.3 General behaviour when handling the product

- Familiarize yourself with the functions and operation of the product. The specified assembly and operating steps and their sequences must be observed.
- Keep unauthorized persons away.
- Wear personal protective equipment always.
- Precautionary operational measures and instructions for the respective work must be observed.
- In addition to these Instructions, general statutory regulations for accident prevention and environmental protection must be observed.
- Precautionary operational measures and instructions for the respective work must be observed. Uncertainty seriously endangers safety.
- Safety-related protective and safety equipment must not be removed, modified or affected otherwise in its function and is to be checked at regular intervals for completeness and function.
- If protective and safety equipment has to be dismantled, it must be reassembled immediately after finishing the work, and then checked for correct function.
- Remedy occurring faults in the frame of responsibilities. Immediately inform your superior in the case of faults beyond your competence.
- Never use parts of the centralized lubrication system or of the machine as standing or climbing aids.

1.4 Intended use

Supply of lubricants.

Use is only permitted within the scope of commercial or economic activity by professional users, in compliance with the specifications, technical data, and limits specified in this manual.

1.5 Persons authorized to use the product

Operator

A person who is qualified by training, knowledge and experience to carry out the functions and activities related to normal operation. This includes avoiding possible hazards that may arise during operation.

Specialist in electrics

Person with appropriate professional education, knowledge and experience to detect and avoid the hazards that may arise from electricity.

Specialist in mechanics

Person with appropriate professional education, knowledge and experience to detect and avoid the hazards that may arise during transport, installation, start-up, operation, maintenance, repair and disassembly.

1.6 Foreseeable misuse

Any usage of the product other than as specified in this manual is strictly prohibited. Particularly prohibited are:

- Use of non-specified consumables, contaminated lubricants, or lubricants with air inclusions.
- Use of C3 versions in areas with aggressive, corrosive substances (e.g., high salt load).
- Use of plastic parts in areas with high exposure to ozone, UV light, or ionizing radiation.
- Use to supply, convey, or store hazardous substances and mixtures as defined in the CLP Regulation (EC 1272/2008) or GHS with acute oral, dermal, or inhalation toxicity or substances and mixtures that are marked with hazard pictograms GHS01-GHS06 and GHS08.
- Use to supply, convey, or store Group 1 fluids classified as hazards as defined in the Pressure Equipment Directive (2014/68/EU) Article 13 (1) a).
- Use to supply, convey, or store gases, liquefied gases, dissolved gases, vapors, or fluids whose vapor pressure exceeds normal atmospheric pressure (1013 mbar) by more than 0.5 bar at their maximum permissible operating temperature.
- Use in an explosion protection zone.
- Use without proper securing against excessively high pressures, in the case of pressurized products.
- Use outside of the technical data and limits specified in this manual.

1.7 Referenced documents

In addition to this manual, the following documents must be observed by the respective target group:

- Company instructions and approval rules
- If applicable:
- Safety data sheet of the lubricant used
 - Project planning documents
 - Supplementary information regarding special designs of the pump. This you will find in the special system documentation.
 - Instructions for other components for setting up the centralized lubrication system.

1.8 Prohibition of certain activities

- Replacement of or modifications to the pistons of the pump elements
- Repairs or modifications to the drive.
- Alterations to the control circuit board beyond adjustment of lubrication times and interval times or replacement in case of defect.
- Alterations to the power supply board beyond replacement in case of defect.

1.9 Painting plastic components and seals

The painting of any plastic components and seals of the products described is prohibited. Completely mask or

remove plastic components before painting the main machine.

1.10 Safety markings on the product

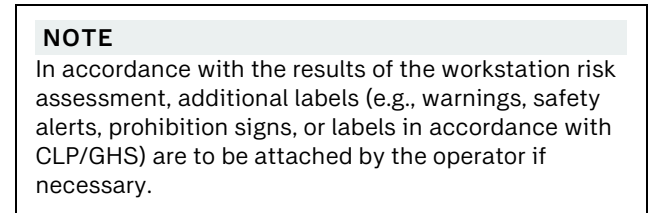
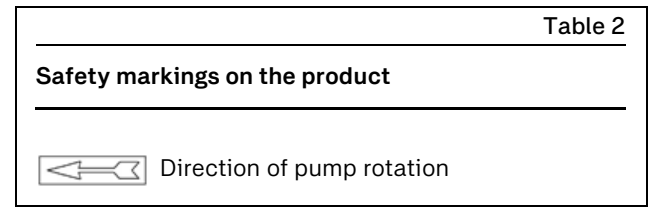

1.11 Note on the type plate

The type plate provides important data such as the type designation, order number, and sometimes regulatory characteristics. To avoid loss of this data in case the type plate becomes illegible, it should be entered in the manual.

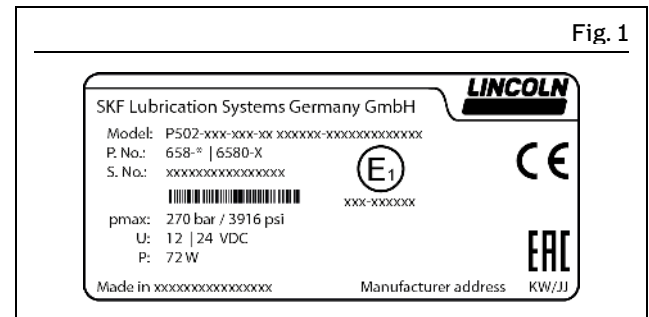

Type plate

1.12 Notes on CE marking

 CE marking is effected following the requirements of the applied directives requiring a CE marking:

- 2014/30/EC Electromagnetic Compatibility
- 2011/65/EU Directive on the restriction of the use of certain hazardous substances in electrical and electronic equipment (RoHS II)

1.13 Note on Low Voltage Directive

The protection objectives of the Low Voltage Directive 2014/35/EU are met in accordance with Annex I, No. 1.5.1 of the Machinery Directive 2006/42/EC.

1.14 Note on Pressure Equipment Directive

Due to its performance characteristics, the product does not reach the limit values defined in Article 4, Paragraph 1, Subparagraph (a) (ii) and is excluded from the scope of Pressure Equipment Directive 2014/68/EU in accordance with Article 1, Paragraph 2 Subparagraph (f).

1.15 Note on UKCA marking



The UKCA conformity marking confirms the product's conformity with the applicable legal provisions of Great Britain.

1.16 Note on UL mark



The UL Mark certifies that the product has UL certification of compliance with U.S. and Canadian safety regulations.

1.17 Note on ECE mark



The ECE test mark (E1) confirms that an ECE type approval (components requiring approval on motor vehicles) has been granted for a product which bears this mark on its type plate.

1.18 Note on EAC marking



The EAC conformity marking confirms the product's conformity with the applicable legal provisions of the Eurasian customs union.

1.19 Note on China RoHS mark



The China RoHS mark confirms that there is no danger to persons or the environment from the regulated substances contained within for the intended period of use (year number shown in the circle).

1.20 Emergency shutdown

This is done by a course of action to be defined by the operator.

1.21 First start-up, daily start-up

Ensure that:

- All safety devices are fully present and functional
- All connections are properly connected
- All parts are correctly installed
- All warning labels on the product are fully present, visible, and undamaged
- Illegible or missing warning labels are immediately replaced.

1.22 Residual risks

Table 3

Residual risks										
Residual risk	Possible in lifecycle						Avoidance / Remedy			
Personal injury / property damage due to falling of hoisted parts.	A	B	C				G	H	K	Unauthorized persons must be kept away. Nobody is allowed to be present below hoisted parts. Lift parts using suitable lifting gear.
Personal injury / property damage due to tilting or falling product due to non-compliance with specified torques.		B	C				G			Adhere to the specified torques. Mount the product only on components with a sufficient load-carrying capacity. If no torques are specified, use those specified for the screw size for screws of strength class 8.8.
Personal injury, property damage due to spilled, leaked lubricant.		B	C	D		F	G	H	K	Be careful when connecting or disconnecting the lubricant lines. Use only hydraulic screw unions and lubrication lines suitable for the specified pressure. Do not mount lubrication lines on moving parts or chafe points. If this cannot be avoided, use anti-kink coils and/or conduits.
Fire hazard or damage to the pump from operation with damaged electrical components, such as power leads and plugs.		B	C	D	E	F	G	H		Inspect electrical components for damage prior to initial use and then at regular intervals. Do not install cables on moving parts or chafe points. If this cannot be avoided, use anti-kink coils and/or conduits.
Damage to the pump from failure to comply with the permissible cyclic duration factor (in the case of pumps without a control circuit board).			C	D						Operate the pump only within the permissible cyclic duration factor.
Bursting of the reservoir when filling with a high-powered pump		B	C	D						Monitor the filling process and stop once the MAX mark on the reservoir is reached
Reservoirs with a follower plate are under spring tension							G			Wait until the tension on the spring has been relieved as much as possible (i.e., the reservoir is empty) before removing the reservoir. Drain the reservoir if necessary. Provide suitable protective measures when loosening the reservoir, e.g., a retaining straps. Do not work with your head directly above the reservoir
Damage to the control circuit board due to electrostatic discharge when replacing							G			Avoid buildup of electrostatic charge. Use ESD tools and ESD clothing and apply a grounding strap
Loss of electrical protection functions due to incorrect installation of the control circuit board							G			A safety check in accordance with DIN EN 60204-1 must be performed after the installation of the control circuit board

Table 3

Residual risks					
Residual risk	Possible in lifecycle			Avoidance / Remedy	
Personal injury / property damage due to falling of hoisted parts.	A	B	C	G H K	Unauthorized persons must be kept away. Nobody is allowed to be present below hoisted parts. Lift parts using suitable lifting gear.
Contact with stirring paddle in "trial run" without reservoir after repair.				G	Operate the pump only with the reservoir

Lifecycle phases: A = Transport, B = Assembly, C = First start-up, D = Operation, E = Cleaning, F = Maintenance, G = Malfunction, repair, H = Shutdown, K = Disposal

2 Lubricants

2.1 General information

Lubricants are selected specifically for the relevant application. The manufacturer or operator of the machine should ideally make the selection in consultation with the supplier of the lubricant. If you have no or little experience in selecting lubricants for lubrication systems, please contact us. We would be happy to assist you in selecting suitable lubricants and components to build a lubrication system optimized for your particular application. Consider the following points when selecting/using lubricants. This will spare you potential downtime and damage to the machine or lubrication system.

2.2 Material compatibility

The lubricants must generally be compatible with the following materials:

- Plastics: ABS, CR, FPM, NBR, NR, PA, PET, PMMA, POM, PP, PS, PTFE, PU, PUR
- Metals: steel, gray cast iron, brass, copper, aluminum.

2.3 Temperature properties

The lubricant used must be suitable for the specific ambient temperature of the product. The viscosity approved for proper functioning must neither be exceeded at low temperatures nor fall too low at high temperatures. For the approved viscosity, see the "Technical data" chapter.

2.4 Aging of lubricants

Based on past experience with the lubricant used, checks should be conducted at regular intervals defined by the operator, to determine whether the lubricant needs to be replaced due to aging processes (oil separation). In case of doubt regarding the continued suitability of the lubricant, it must be replaced before the system is started up again. If you do not yet have any experience with the lubricant used, we recommend conducting a check after just one week.

2.5 Avoidance of faults and hazards

To avoid faults and hazards, please observe the following:

- When handling lubricants, observe the relevant safety data sheet (SDS) and any hazard labeling on the packaging.
- Due to the large number of additives, some lubricants that meet the pumpability requirements specified in the manual are not suitable for use in centralized lubrication systems.
- Whenever possible, always use SKF lubrication greases. They are ideal for use in lubrication systems.
- Do not mix lubricants. This can have unpredictable effects on the properties and usability of the lubricant.
- Use lubricants containing solid lubricants only after technical consultation with SKF.
- The lubricant's ignition temperature has to be at least 50 kelvin above the maximum surface temperature of the components.

2.6 Solid lubricants

Solid lubricants may only be used after prior consultation with SKF. When solid lubricants are used in lubrication systems, the following rules generally apply:

Graphite:

- Maximum graphite content 8%
- Maximum grain size 25 µm (preferably in lamellar form).

MoS₂:

- Maximum MoS₂ content 5%
- Maximum grain size 15 µm.

Copper:

- Lubricants containing copper are known to lead to coatings forming on pistons, bore holes, and mating surfaces. This can result in blockages in the centralized lubrication system.

Calcium carbonate:

- Lubricants containing calcium carbonate are known to lead to very heavy wear on pistons, bore holes, and mating surfaces.

Calcium hydroxide:

- Lubricants containing calcium hydroxide are known to harden considerably over time, which can lead to failure of the centralized lubrication system.

PTFE, zinc, and aluminum:

- For these solid lubricants, it is not yet possible to define any limit values for use in lubrication systems on the basis of existing knowledge and practical experience.

2.7 Chisel pastes

Due to their high resistance to pressure and temperature, chisel pastes are used to reduce wear on insert tools and wear bushings on hydraulic and pneumatic hammers, stone crushers and hydraulic grabs. Before use, observe the safety data sheet (SDS) and the technical data and application limits of the respective chisel paste.

Chisel pastes may be pumped only with SKF pumps and pump elements developed for this application.

Chisel pastes are special lubricants and must not be used as a lubricant for bearings.

Grease guns filled with chisel paste must be permanently marked with a corresponding note.

NOTE

The use of chisel paste requires prior consultation with the SKF Product Management.

3 Overview, functional description

In the following you will find an overview of the most important functions and equipment features of the pump:

3.1 Described versions

The following versions of the P502 are described in these instructions:

3.1.1 P502 with follower plate

- With follower plate and low-level signal (1XLF)
- With and without control
- 12 / 24 V DC
- For lubrication grease

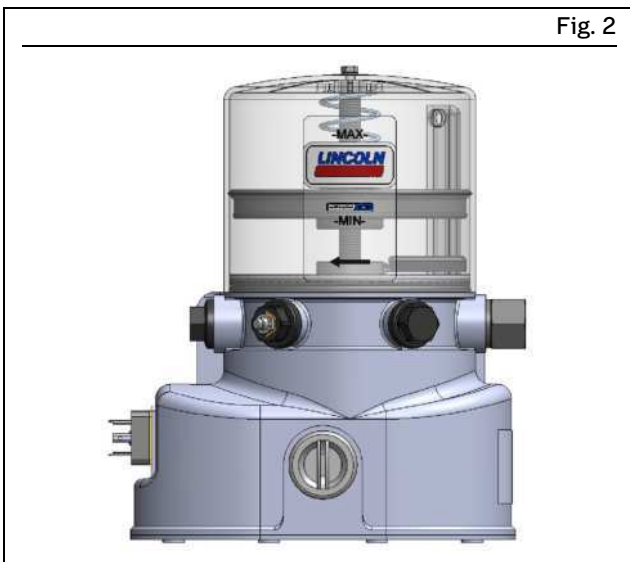

P502 with follower plate

3.1.2 P502 without follower plate

- Without follower plate and low-level signal (1XN)
- With and without control
- 12 / 24 V DC
- For lubrication grease

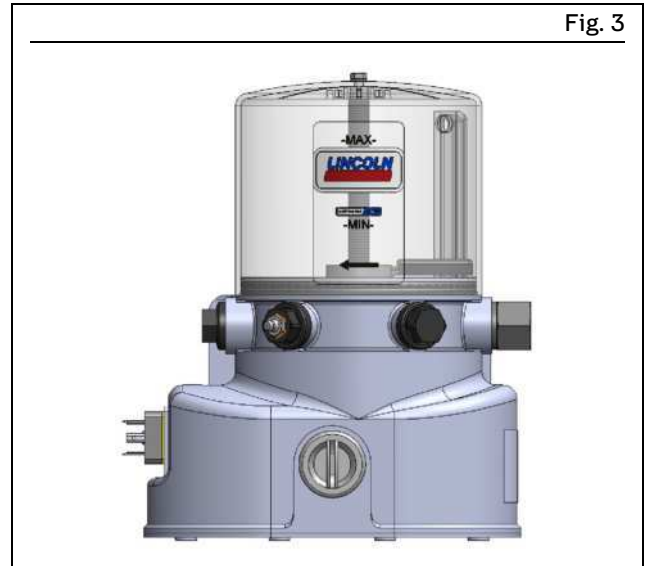

P502 without follower plate

3.2 Overview/functional description

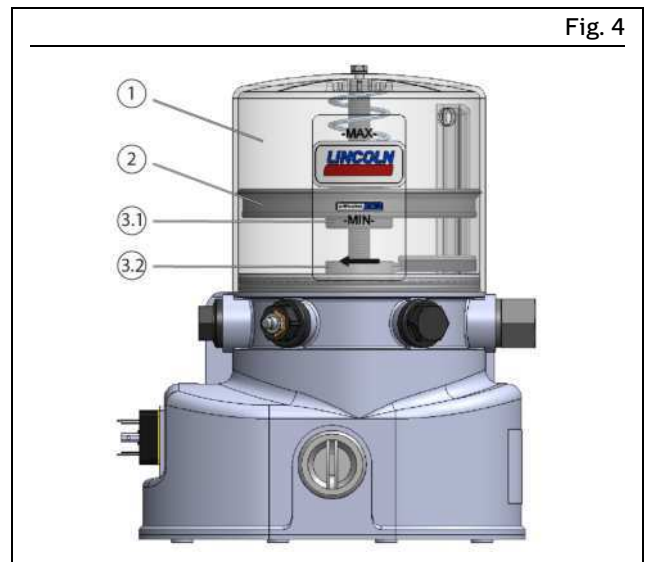

Overview of P502

1 Reservoir

The reservoir stores the lubricant. There are two different reservoir designs, depending on the pump version:

1. XN 1 L without follower plate and without low-level signal
2. XLF 1 L with follower plate and low-level signal

2 Follower plate (in models with a follower plate)

The follower plate, under the force of a spring, presses the lubricant down into the area of the pump elements. This improves the suction characteristics of the pump. Pumps with a follower plate can also be used in rotating applications (e.g., wind turbines).

3.1 / 3.2 Magnet and reed switch for low-level signal

The low-level signal is contactless, using a magnet (3.1) in the follower plate and a reed switch (3.2) in the pump

housing. An low-level signal is triggered when the - MIN - fill level is reached in the reservoir.

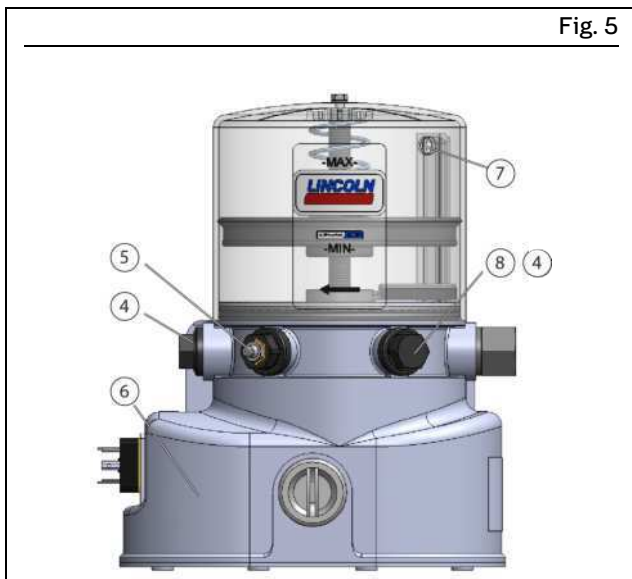

Overview of P502

4 Plug screw

If the pump is used with only one pump element, the connection for the second pump element must be sealed off with the plug screw.

5 Filler nipple (R1/4)

The filler nipple can be used to fill the reservoir with lubricant.

6 Pump housing

This contains the motor and (depending on the pump version) various control circuit boards and possible connections (rectangular/bayonet connector or M12 connector).

7 Reservoir ventilation

This is used for bleeding the reservoir when filling with lubricant and for ventilation of the reservoir during operation.

8 Return connection

This is used for connecting a return line or for filling the reservoir via a hand pump with a corresponding adapter. When the pump is delivered, the return connection is sealed off with a plug screw (4).

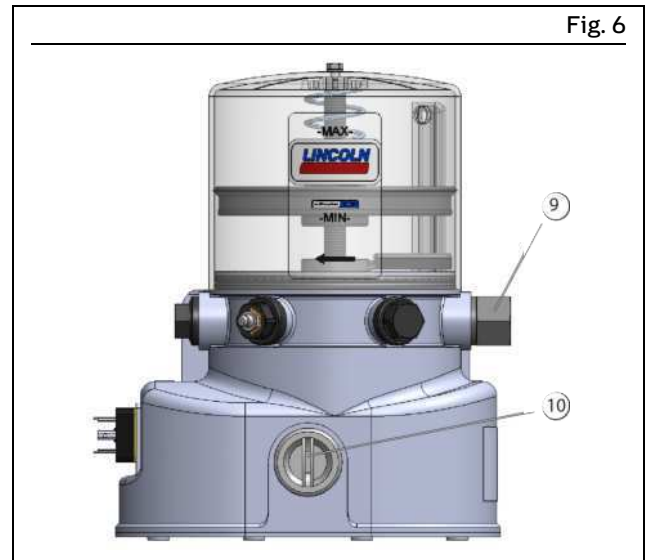

Overview of P502

9 pump element

Up to 2 pump elements can be installed. The pump elements are driven by the motor via an eccentric. The pump elements generate the operating pressure and pump the lubricant from the reservoir into the connected lubrication lines. Each pump element must be safeguarded with a pressure limiting valve so that the max. operating pressure is not exceeded.

10 Control circuit board sealing cap

In the case of pumps with control, operational and fault states (shown by LED indicators on the control circuit board) can be viewed through the transparent sealing cap. The sealing cap (10) must be removed in order to trigger additional lubrication or to set the lubrication time and pause time on the control circuit board.

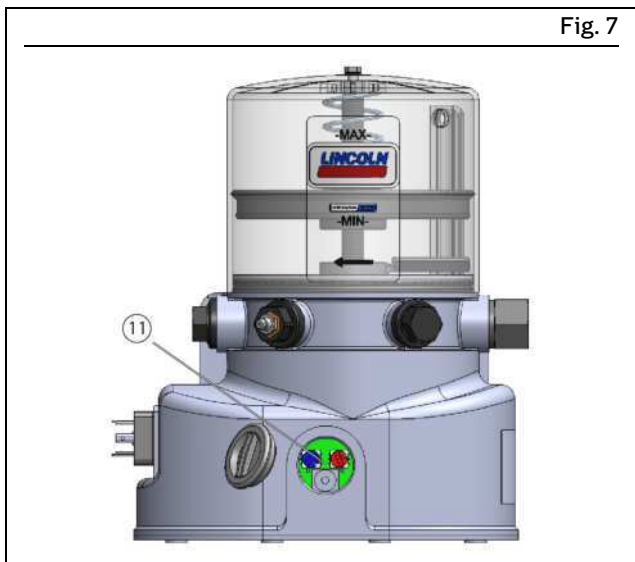

Overview of P502

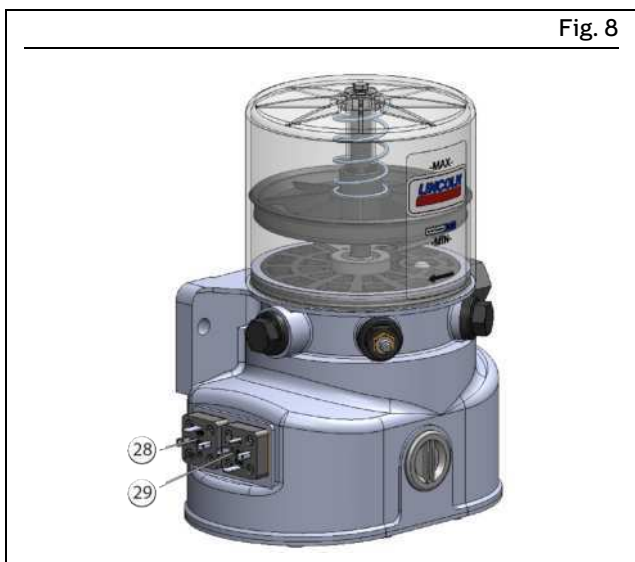

Overview of P502

11 Control circuit board

All control circuit boards are equipped with an EEPROM. This protects the control circuit board from data loss. If the pump is switched off, the pause time or lubrication time resumes at the point of interruption when the pump is switched back on.

28/29 Electrical connections

The electrical connections on the left and possibly also right sides of the pump housing are used for connecting to the external power supply (28) and to external control or output devices (29) (e.g., PLC, control lights).

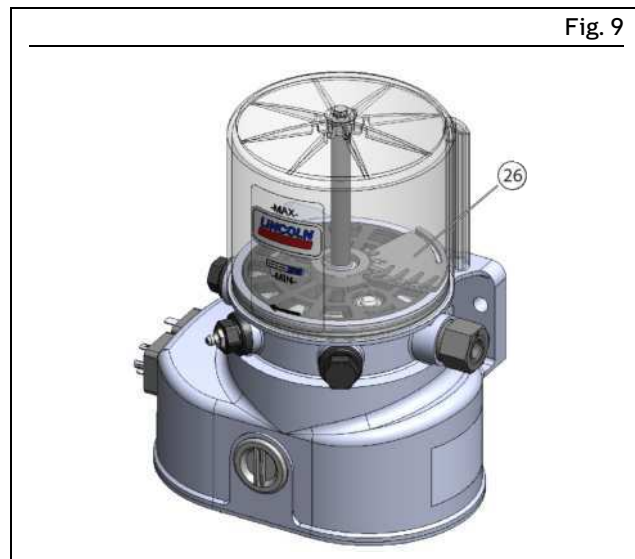

Overview of P502

26 Stirring paddle

The stirring paddle homogenizes and smooths the lubricant. Its pumpability is improved as a result, and the oil separation of lubricant is reduced.

4 Technical data

Table 4

General technical data							
Operating pressure	Max. 270 bar	Mounting position ²⁾	Vertical				
Ambient temperature ¹⁾	-25 °C to 70 °C	Sound pressure level	< 70 dB (A)				
Pump elements	Max. 2	Weight (empty)	4 kg				
Reservoir capacity ³⁾	1 liter nominal						
Feedable lubricants	Lubrication greases from NLGI 00 up to and including NLGI 2 ⁶⁾						
Filling	Filler nipple Filler coupling Cartridge filling						
Nominal delivery rate⁴⁾ of the individual pump elements							
Pump element	L5	K5	K6	K7	B7	C7	KR
Delivery rate per stroke(ccm)	0.03	0.10	0.16	0.22	0.10	0.24	004-0.18
Electrical data							
		12 VDC pump		24 VDC pump			
Rated voltage		12 VDC ± 10 %		24 VDC ± 10 %			
Current input, max.		6.5 A		3 A			
Recommended back-up fuse		6.0 A (slow)		3.0 A (slow)			
Nominal speed		9 ±1 rpm		9 ±1 rpm			
Tolerance for input voltage		-20 / + 30 %		-20 / + 30 %			
Inputs	Protected against polarity reversal, short-circuit-proof, non-isolated						
Enclosure ratings							
IP enclosure rating (ISO 20653) ⁵⁾		Rectangular connector	IP6K9K				
		Bayonet connector	IP 65				
		M12 connector	IP67				
Protection classes		SELV, PELV, FELV					

¹⁾ The lower limit for the permissible ambient temperature is contingent on the pumpability of the lubricants used.

²⁾ Rotary installation is possible for pumps with a follower plate, e.g., in wind turbines. Maximum speed and maximum distance to the rotational axis can be specified on request.

³⁾ About 1.2 liters of lubricant are needed to fill a newly delivered empty pump, as the space below the intermediate base has to be filled with lubricant initially.

⁴⁾ The nominal delivery rate for the pump elements is based on NLGI Grade 2 lubrication greases at an ambient temperature of +20°C and a back pressure of 100 bar on the pump element.

⁵⁾ The specified enclosure rating is contingent on the use of appropriate connection sockets and cables. If connection sockets and cables with a lower protection rating are used, the lowest of the protection ratings will apply.

⁶⁾ Lubrication greases of NLGI Grade III can be pumped only under particular operating conditions. These operating conditions must be clarified with SKF in advance.

4.1 Factory settings of the lubrication and pause times for pumps with control circuit board

Table 5

Lubrication time and pause time		
Lubrication time	6 min.	The red rotary switch on the control circuit board is in position 3
Pause time	6 hrs.	The blue rotary switch on the control circuit board is in position 6
Low-level signal		
The maximum running time after a low-level signal is 4 minutes. When this time expires, the control stops the pump until the low-level signal is switched off by filling the reservoir.		

4.2 Required values of the lubrication and pause times for pumps without control circuit board

Table 6

To prevent damage to the pump, the external control must adhere to the following values.	
Lubrication time and pause time	
Lubrication time	At least 8 seconds / maximum 30 minutes
Pause time	At least 4 minutes
Low-level signal	
The operator must ensure that the pump is stopped by the external control no later than 4 minutes after the empty signal.	

4.3 Possible settings of the lubrication and pause times for pumps with control circuit board

Table 7

Position of the rotary switch (blue)	1	2	3	4	5	6	7	8	9	A	B	C	D	E	F
Pause time in minutes ³⁾	4	8	12	16	20	24	28	32	36	40	44	48	52	56	60
Position of the rotary switch (blue)	1	2	3	4	5	6	7	8	9	A	B	C	D	E	F
Pause time in hours ³⁾	1	2	3	4	5	6	7	8	9	10	11	12	13	14	15
Position of the rotary switch (red)	1	2	3	4	5	6	7	8	9	A	B	C	D	E	F
Lubrication time in seconds ³⁾	8	16	24	32	40	48	56	64	72	80	88	96	104	112	120
Position of the rotary switch (red)	1	2	3	4	5	6	7	8	9	A	B	C	D	E	F
Lubrication time in minutes ³⁾	2	4	6	8	10	12	14	16	18	20	22	24	26	28	30
<p>Note on the "0" position of the rotary switches</p> <p>Never turn the rotary switches to the "0" position. This position is intended solely for the purposes of the manufacturer. In the "0" position, the pump operates with its factory settings (see section 4.3) and fault F2 (see the relevant section of these instructions) is displayed on the LEDs of the control circuit board.</p>															

³⁾ The time values for the lubrication time and pause time are set at the factory using the jumpers on the control circuit board (see the relevant section of these instructions). If possible, the operator should not change the position of the jumpers.

4.4 Tightening torques

Table 8

The torques specified below must be observed during assembly and repair of the pump.

Pump on base, machine, or vehicle	19	Nm
Pump element on pump housing	20	Nm
Pressure limiting valve in pump element	8	Nm
Grease nipple / adapter for grease nipple	10	Nm
Plug screws on the housing cover	0.8	Nm
Reservoir on reservoir axle	2+1	Nm

4.5 Lubricant requirement when an empty pump is filled for the first time

Table 9

The following volumes of lubricant are required in order to fill a new empty pump up to the MAX mark on the reservoir.

1 XLF	Approx. 1.25 liters
1 XN	Approx. 1.40 liters

The difference between the lubricant volume actually required for initial filling and the nominal volume of the reservoir is due to the filling of the space in the pump housing up to the MIN mark on the reservoir

4.6 Usable reservoir volume

Table 10

Reservoir 1 XN (without follower plate and without low-level signal)

The usable reservoir volume in reservoir design 1 XN is strongly dependent on the consistency (NLGI Grade) and working temperature of the lubricant used. With high consistency and a low working temperature, more lubricant typically adheres to the inner surfaces of the reservoir/pump, leaving less lubricant available to be pumped.

1XN	
Lubricants with relatively low consistency ⁴	About 1.0 liter (without vibrations/tilting)
Lubricants with relatively low consistency ^{4,6)}	About 0.5 liter (with relatively strong vibrations/tilting)
Lubricants with relatively high consistency ⁵⁾	Approx. 0.75 liters

1 XLF
With reservoir design 1XLF, the usable reservoir volume does not depend on the consistency of the lubricant.

⁴⁾ Consistencies of NLGI 000 lubricants at +70°C up to consistencies of NLGI 1.5 lubricants at +20°C.

⁵⁾ Consistencies of NLGI 2 lubricants at +20°C up to the maximum permissible lubricant consistency.

⁶⁾ When using lubricants with relatively low consistency in pumps subjected to strong vibrations or tilting motions (e.g., heavy equipment for construction or agriculture), maintain a clearance of about 15 mm below the MAX mark on the reservoir. This stops lubricant from entering the reservoir ventilation. In the case of very strong vibrations, this value must be increased, and in the case of minimal vibrations, it can be reduced. Changing the filling height by 10 mm equates to a change in volume of approx. 0.14 liters.

Example: P502- 1XN -2K6-12-1A1.10-V10

P502 - 1XN -2K6 -12 -1A 1 . 14-V1
0

Type series

P502 Pump for lubrication grease

Reservoir designs (plastic)

1XN 1 L for lubrication grease
(without follower plate and without low-level signal)

1XLF 1L for lubrication grease
(with follower plate and with low-level signal)

Pump elements

... Without pump elements

[X] L5 Piston diameter = 5 mm

[X] K5 Piston diameter = 5 mm

[X] K6 Piston diameter = 6 mm

[X] K7 Piston diameter = 7 mm

[X] B7 Piston diameter = 7 mm

[X] C7 Piston diameter = 7 mm

[X] KR Piston diameter = 7 mm

[X] Number of pump elements (max. 2)

Supply voltage

12 12 VDC

24 24 VDC

Electrical connections on the pump

1A 1 connection
Connection on the left for power supply voltage, low-level signal, and illuminated pushbutton

2A 2 connections
Connection on the left for power supply voltage
Connection on the right for low-level signal and illuminated pushbutton

Connection type

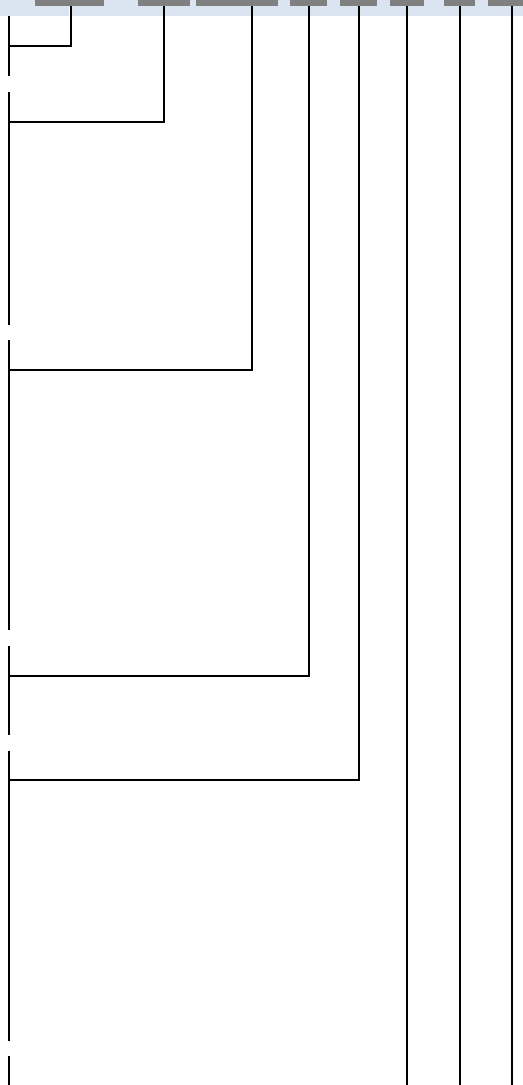

Example: P502- 1XN -2K6-12-1A1.10-V10

P502 - 1XN -2K6 -12 -1A 1 . 14-V1

0

- 1 Rectangular connector
- 2 M12 connector
- 5 Bayonet connector ISO 15170-1, 4/4-pin
- 7 Bayonet connector ISO 15170-1, 7/6-pin

Connections from the pump to external devices

- 00 Rectangular connector with cap plug
- 01 ¹⁾ Rectangular connector / M12 connector with connection socket
- 10 Rectangular connector with connection socket and 10 m cable
- 14 Bayonet connector with 10 m cable (4/4-core)
- 16 Bayonet connector with 10 m cable (7/6-core)

Control circuit boards

- Without control circuit board
- V10 Control circuit board V10 – V13 (power supply voltage on terminals 15 + 31)
- V20 Control circuit board V20 – V23 (power supply voltage on terminals 15+ 30 + 31)

¹⁾ With connection type 2A2.01, the two M12 connectors cannot be fitted vertically, but instead only at an angle downward

5 Delivery, returns, storage

5.1 Delivery

After receipt of the shipment, it must be inspected for any shipping damage and for completeness according to the shipping documents. Immediately inform the transport carrier of any shipping damage. The packaging material must be preserved until any discrepancies are resolved.

5.2 Return shipment

Before return shipment, all contaminated parts must be cleaned. If this is not possible or practical, e.g. if it would impede fault detection in the case of complaints, the medium used must always be specified. In the case of products contaminated with hazardous substances as defined by GHS or CLP regulations, the safety data sheet (SDS) must be sent with the product and the packaging must be labelled in accordance with GHS/CLP. There are no restrictions for land, air, or sea transport. The choice of packaging should be based on the specific product and the stresses to be expected during transport (e.g., necessary anti-corrosion measures in the case of shipment by sea). In the case of wooden packaging, the applicable import regulations and the IPPC standards must be observed. Required certificates must be included in the shipping documents. The following information, as a minimum, must be marked on the packaging of return shipments.



Marking of return shipments

5.3 Storage

The following conditions apply to storage:

- Dry, low-dust, vibration-free, in closed rooms
- No corrosive, aggressive substances at the storage location (e.g., UV rays, ozone)
- Protected against animals (insects, rodents)
- If possible, keep in the original product packaging
- Protected from nearby sources of heat or cold
- In the case of large temperature fluctuations or high humidity, take appropriate measures (e.g., heating) to prevent the condensation of water
- Before usage, check products for damage that may have occurred during storage. This applies in particular to parts made of plastic (due to embrittlement).

5.4 Storage temperature range

For parts not filled with lubricant, the permitted storage temperature is the same as the permitted ambient temperature range (see “Technical data”).

5.5 Storage conditions for products filled with lubricant

For products filled with lubricant, the permitted storage temperature range is:

minimum	+ 5 °C	[+41 °F]
maximum	+ 35 °C	[+95 °F]

If the storage temperature range is not maintained, the following steps for replacing the lubricant may not lead to the desired result under certain circumstances.

5.5.1 Storage period up to 6 months

Filled products can be used without implementing additional measures.

5.5.2 Storage period between 6 and 18 months

Pump:

- Connect the pump to a power source
- Switch on the pump and run it until lubricant comes out of every outlet without air bubbles
- Disconnect the pump from the power source
- Remove and dispose of the lubricant that came out

Lines:

- Remove pre-installed lines
- Ensure that both ends of the line are open
- Fill the lines completely with fresh lubricant

Metering devices:

NOTE

Due to the large number of different metering devices, no universally valid statement can be made regarding the removal of the old lubricant and correct bleeding after filling with new lubricant. The instructions can be found in the technical documentation of the specific metering device used.

5.5.3 Storage period more than 18 months

To prevent faults, the manufacturer should be consulted before start-up. The basic procedure for removal of the old lubrication filling corresponds to that for storage periods between 6 and 18 months.

5.6 Declaration of decontamination

If the product came in contact with harmful substances, make sure to thoroughly clean the product before returning it to us. Due to statutory provisions and for the safety of our employees and operation facilities we further need a fully completed and signed “Declaration of decontamination”.

6 Assembly

Observe the safety instructions and the technical data in this manual. Additionally, during assembly pay attention to the following:

- Only qualified and authorized technical personnel may install the products described in this manual.
- Adhere to safety distances and legal prescriptions on assembly and prevention of accidents.
- Possibly existing visual monitoring devices, e.g. pressure gauges, MIN/MAX markings, oil inspection glasses must be clearly visible.
- Protect the product against humidity, dust and vibrations.
- Install the product in an easily accessible position. This facilitates other installations, control and maintenance work.

6.1 Mounting dimensions

In order to have sufficient space for maintenance work or for the attachment of additional components for the construction of a centralized lubrication system on the pump, a clearance of at least 100 mm should be provided for in every direction in addition to the specified dimensions.

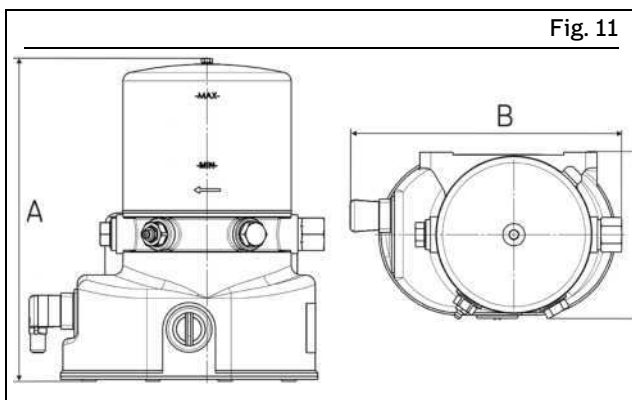

Mounting dimensions

A = 270 mm (height)
 B = 250 mm (width)
 C = 150 mm (depth)

6.2 Assembly holes

NOTICE

Possible damage to the main machine and the pump

The assembly holes should be created only on non-load-bearing parts of the main machine. Do not fasten on two parts which move in opposite directions to one another (e.g., machine base and machine assembly). When installing, always use the accompanying mounting brackets and washers and comply with the specified torques.

Fasten at the fastening points (27) using the fastening hardware included with the pump:

- 2 x M8 screws
- 2 x nuts (self-locking)
- 2 x washers

Tightening torque = 18 Nm ± 1,0 Nm

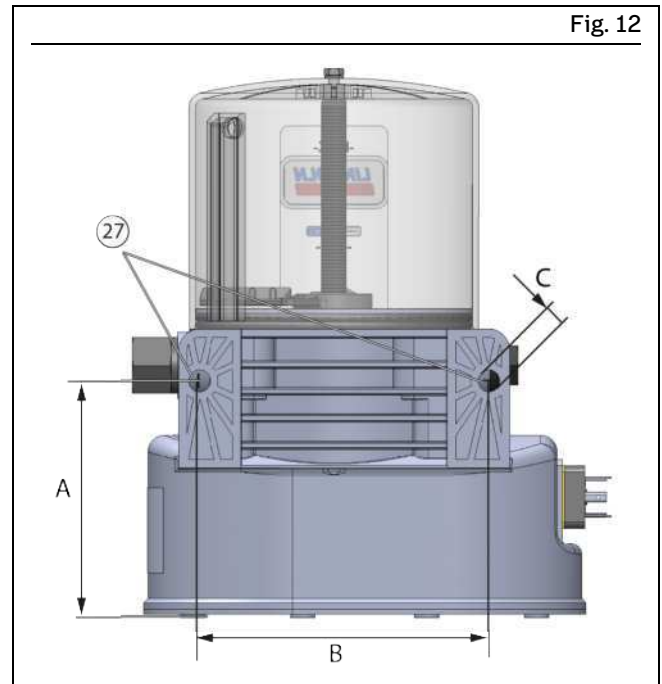

Fastening points

A = 114 mm (height)
 B = 140 mm (clearance)
 C = 10 mm (diameter of hole)

6.3 Installing the pump element

1. Remove the plug screw (4).
2. Screw in the pump element (9) with a new packing ring.
3. Repeat the procedure on each pump element.

Tightening torque = 20 Nm

Fig. 13

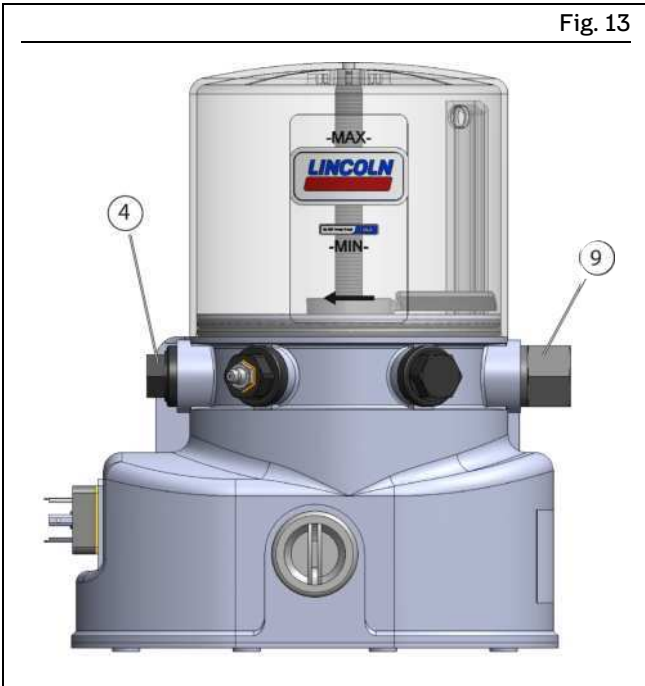

Installing pump elements

6.4 Setting the delivery rate on pump element R or KR

NOTE

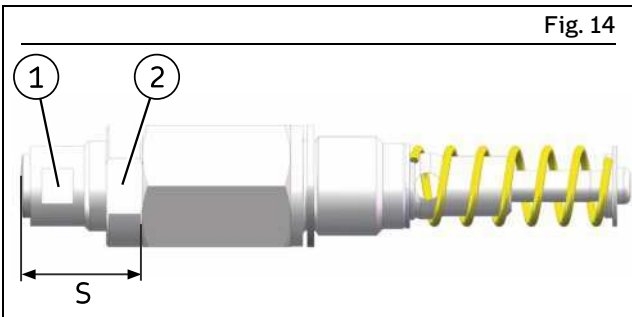

The delivery rate of pump element R or KR can be adjusted only when the pump is at a standstill. When delivered, the rate is set to full delivery, meaning the setting dimension is $S = 29 \text{ mm}$ [1.14 in.].

Fig. 14



Setting the delivery rate on pump element R / KR

To set the delivery rate, proceed as follows:

1. Release the locknut (Fig. 14/2).
2. Set the delivery rate by turning the spindle (Fig. 14/1) to the dimension specified in the chart below (Fig. 15).
 -  = lower delivery rate
 -  = higher delivery rate
3. Once the delivery rate is set, tighten the locknut (Fig. 14/2) again.

NOTE

The torque for tightening the locknut is $20 \text{ Nm} \pm 2.0 \text{ Nm}$ [14.75 ft.lb. \pm 1.4 ft.lb.]

Fig. 15

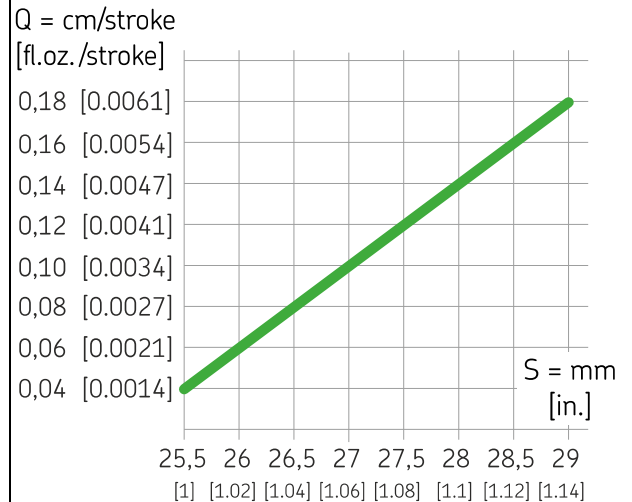

Delivery rate on pump element R or KR

Legend to Figure:

- Q Delivery rate of the pump element in ccm/stroke [fl.oz./stroke]
- S Thread engagement depth S (Fig.14) in mm [in.]

NOTE

Be sure to observe the formula for temperature-dependent calculation of the delivery rate using the example of a high-temperature grease, given in these instructions.

6.5 Installing the pressure limiting valve

Each pump element must be secured with a pressure limiting valve that is suitable for the maximum permissible operating pressure intended for the centralized lubrication system. You can find suitable pressure limiting valves in the spare parts and accessories section of this manual.

1. Select a pressure limiting valve (13) according to the maximum operating pressure.
2. Remove the blind plug in the pump element (9).
3. Screw the pressure limiting valve (13) into the pump element (9).
4. Repeat the procedure on each pump element.

Tightening torque = 8 Nm

Fig. 16

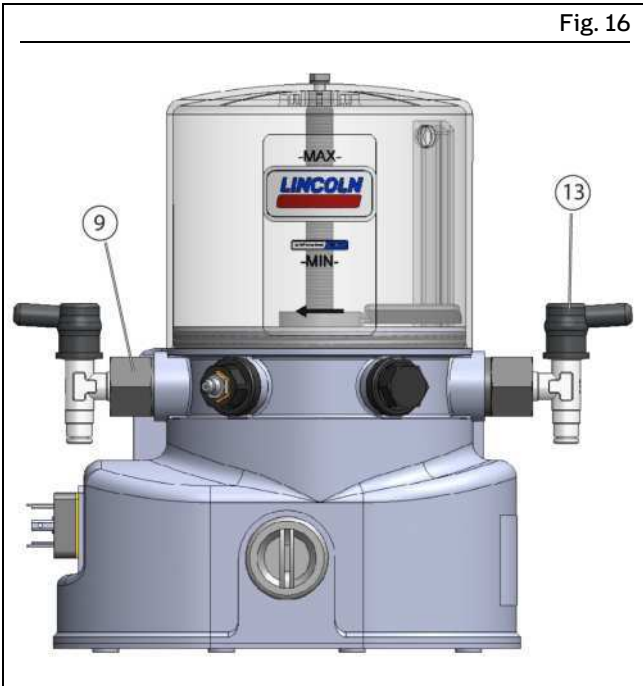

Installing the pressure limiting valve

6.6 Installing the centralized lubrication system

1. Fasten the pump. (Mounting and connection dimensions: see the specifications in this section)

Tightening torque = 18 Nm

2. Pre-assemble and fasten the metering devices (see the relevant instructions for the metering device).
3. Prepare lubrication piping that is suitable for the maximum permissible pressure and attach it to the pump and (if applicable) the main machine. (See the relevant specifications from the manufacturer of the lubrication piping and the fittings).

Fig. 17

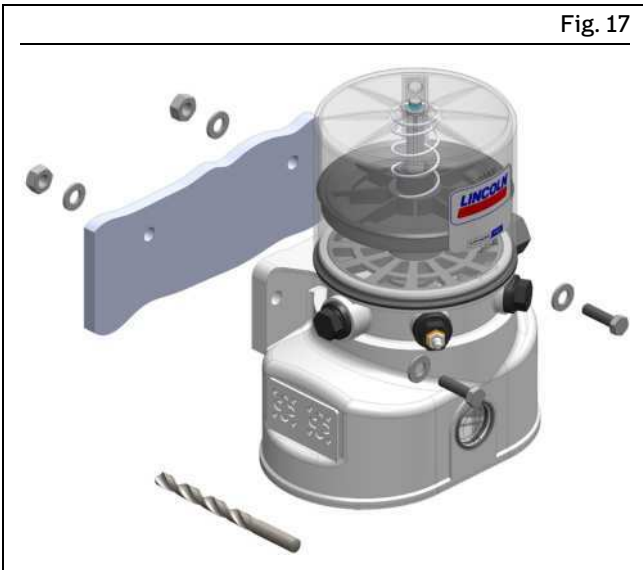

Installing the pump

Fig. 18

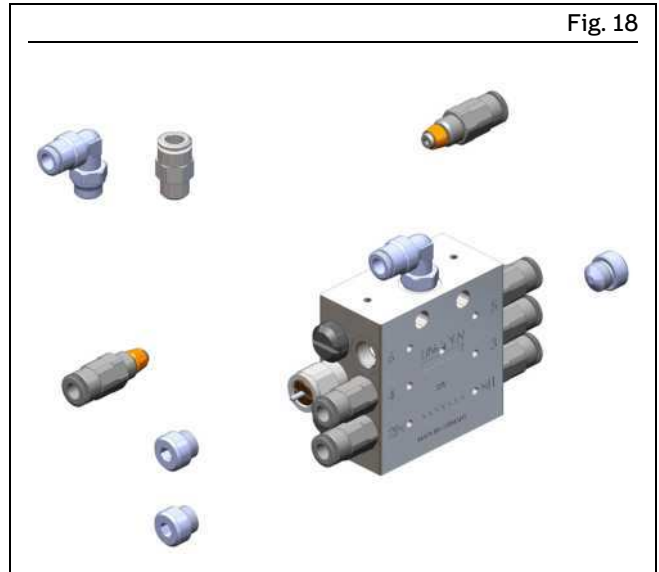

Pre-assembling the metering devices

Fig. 19

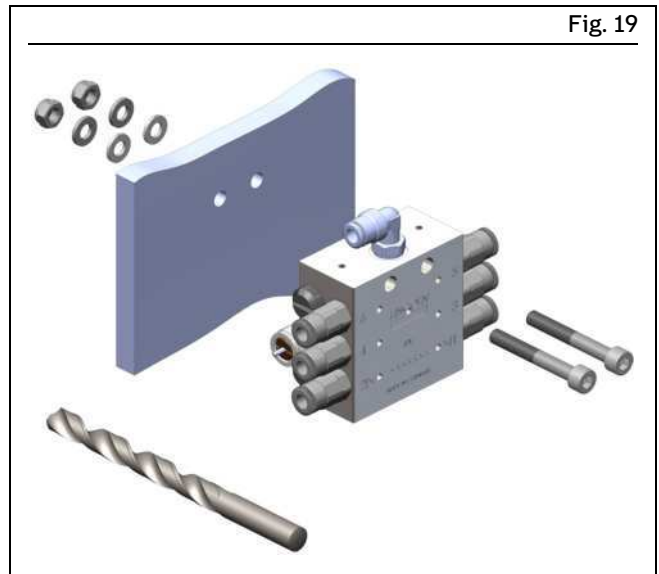

Installing the metering devices

6.7 Connection of the lubrication line

CAUTION



Risk of slipping

Exercise caution when handling lubricants. Immediately remove and bind any leaked lubricants.

NOTICE

Damage to the higher-level machine caused by faulty planning of the centralized lubrication system

All parts for the construction of the centralized lubrication system must be designed for the maximum operating pressure that occurs, the permissible ambient temperature range, the required delivery volume, and the lubricant to be supplied.

Observe the following assembly information for safe and trouble-free operation:

- Generally valid regulations and company regulations regarding the laying of pressurized pipe and hose lines must be observed.
- Use only clean, pre-filled components and lubrication piping.
- Secure every lubricant line on the pump against excessive pressure through the use of a suitable pressure limiting valve (only in the case of pumps without an internal pressure limiting valve).
- The main lubricant line should be routed on a rising gradient and should be able to be bled at the highest point. Lubrication lines should always be arranged so that air inclusions cannot form anywhere.
- Install lubricant metering devices at the end of the main lubricant line such that the outlets of the lubricant metering devices point upwards wherever possible.
- If the system configuration requires that the lubricant metering devices be arranged below the main lubricant line, they should not be placed at the end of the main lubricant line.
- The flow of lubricant should not be impeded by the presence of sharp bends, angle valves, flap valves, seals protruding inward, or changes in cross-section (large to small). Unavoidable changes in the cross-section in lubrication lines must have smooth transitions.
- Connect the lubricant lines in such a way that no mechanical forces are transferred to the product (stress-free connection).
- Lubrication piping is to be positioned in such a way that they cannot become kinked, pinched or frayed.

Fig. 20

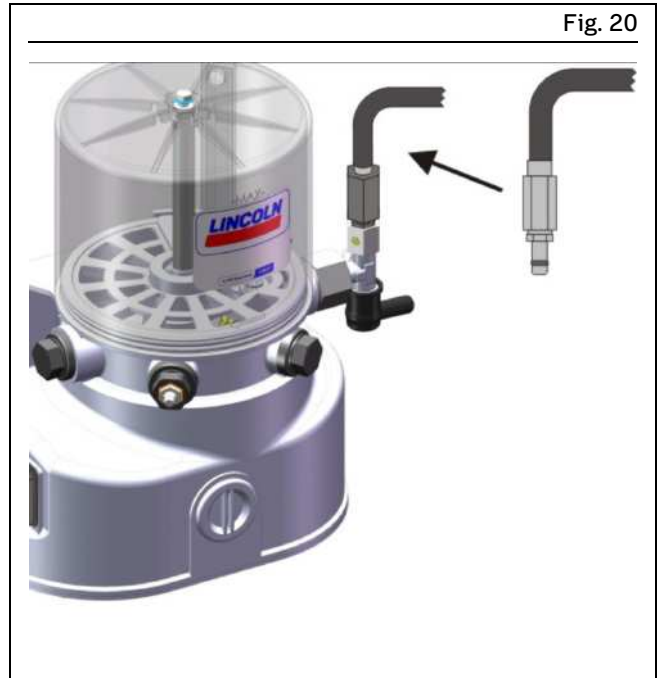

Installing the lubrication piping

6.8 Electrical connection

WARNING



Electric shock

Work on electrical components may be performed only by qualified electricians.



At a minimum, the following safety measures must be taken before any work on electrical components is done:

- Isolate, lock and tag out
- Check to ensure the absence of voltage
- Ground and short-circuit the product
- Cover any live parts in the surrounding area

Observe the following instructions for a safe connection:

- The electrical connection must be implemented in accordance with the specifications of the standards of the DIN VDE 0100 series or of the standards of the IEC 60364 series, respectively.
- Connect the electrical lines in such a way that no mechanical forces are transferred to the product.
- The pump must be secured with a suitable external fuse (see terminal diagram).

The electrical connection is established in accordance with the type of connection of the specific pump.

1. Assemble the required cables in accordance with the respective connection diagram or use preassembled cables for the connection.
2. Connect plugs with their respective bushes and secure them against becoming loose using the type of securing method specified for the quick disconnect couplings. Only this way is a safe connection and compliance with the enclosure rating secured.

NOTE

Connect the cables in such a way that no tensile forces can be transferred to the product.

NOTE

The electrical connection is established in accordance with the type of connection of the specific pump.
 Assemble the required cables in accordance with the respective connection diagram or use preassembled cables for the connection.
 Connect plugs with their respective bushes and secure them against becoming loose using the type of securing method specified for the quick disconnect couplings. Only this way is a safe connection and compliance with the enclosure rating secured.
 Observe the electrical characteristics of the pump in the "Technical data" section.

Rectangular connector

1. Configure the rectangular connector without cable by attaching a suitable cable to it. For connection of the cable, see the wiring diagram on the rectangular connector or the corresponding wiring diagram in these instructions.
2. Remove the protective caps on the electrical connections of the pump.
3. Place the rectangular connector with seal on the connections and fasten using the screw of the rectangular connector.

Bayonet connector

1. Configure the bayonet connector without cable by attaching a suitable cable to it. For connection, see the corresponding wiring diagram in these instructions.
2. Remove the protective caps on the electrical connections of the pump.
3. Place the connector on the connections and fasten by turning.

M12 connector

1. Configure the M12 connector without cable by attaching a suitable cable to it. For connection, see the corresponding wiring diagram in these instructions.
2. Remove the protective caps on the electrical connections of the pump.
3. Place the M12 connector on the connections and fasten by turning.

Fig. 21



Electrical connection

NOTE

In the case of connection type 01 (see the type identification code), the two connectors cannot be fitted vertically as shown above. With this connection type, the two connectors point downward at an angle.

6.9 Initial filling with a follower plate**NOTICE**

Prevent air inclusions under the follower plate. These impair or prevent the pumping function of the pump. When filling, make sure no contamination enters the reservoir. Do not switch on the pump until the cable tie is removed. Bear in mind the expansion of the lubricant due to increased temperature (e.g., during storage or transportation of the pump) and due to pressure relief after the filling procedure – this expansion could cause lubricant to block the reservoir ventilation point and/or to contaminate transport packaging.

6.9.1 Filling via filler nipple

1. Make sure that the pump is standing straight and that the cable tie (30) is at the highest possible position.
2. Place the fill connection of the filling pump on the R1/4 filler nipple (5).
3. Switch on the filling pump and fill the space under the follower plate completely with lubricant. The space is filled completely when the follower plate starts to rise.
4. Turn off the filling pump.
5. Slowly pull the cable tie (30) (for bleeding the air from the space under the follower plate) out of the reservoir ventilation (7).
6. Using the filling pump, fill the reservoir with lubricant up to just below the -MAX- mark.
7. Remove any lubricant that came out and dispose of it in environmentally friendly manner.

Fig. 22

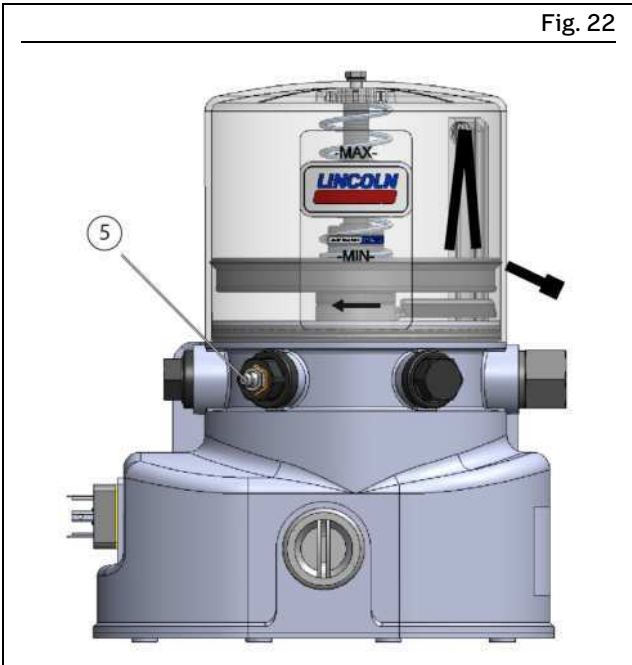

Unfilled pump with cable tie

Fig. 24

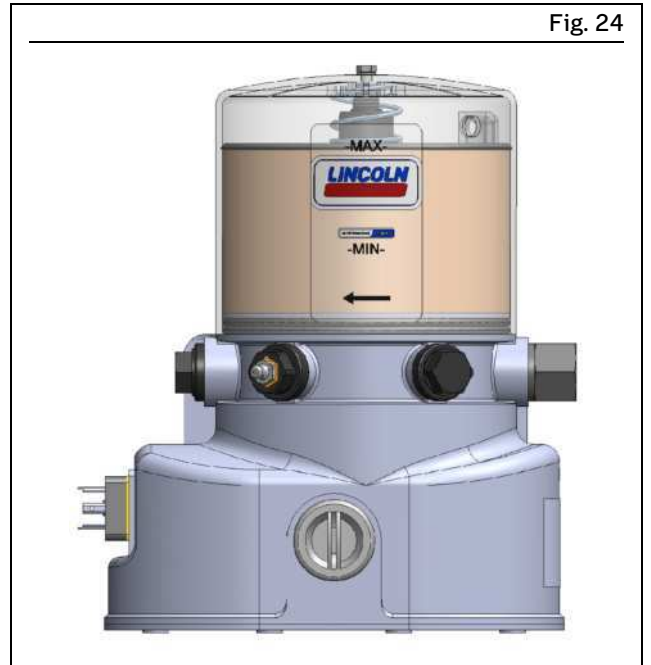

Pump filled and cable tie removed

Fig. 23

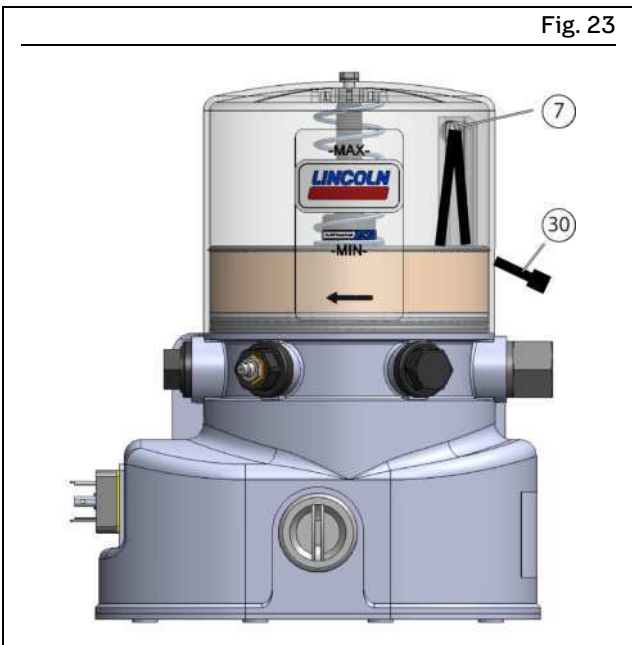

Space under follower plate bled of air

6.9.2 Filling via fill connection

1. Make sure that the pump is standing straight and that the cable tie (30) is at the highest possible position.
2. Unscrew the plug screw from the fill connection (8).
3. Screw in the connection of the cartridge.
4. Fill the space under the follower plate completely with lubricant. The space is filled completely when the follower plate starts to rise.
5. Slowly pull the cable tie (30) (for bleeding the air from the space under the follower plate) out of the reservoir ventilation (7).
6. Now fill the reservoir with lubricant up to just below the -MAX- mark.
7. Unscrew and remove the connection of the cartridge and insert the plug screw into the fill connection.

Tightening torque = 10 Nm

8. Remove any lubricant that came out and dispose of it in environmentally friendly manner.

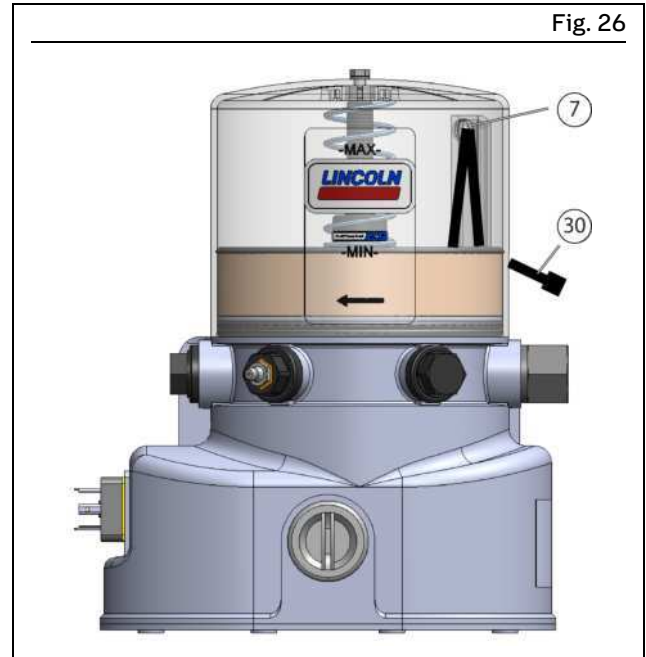

Space under follower plate bled of air

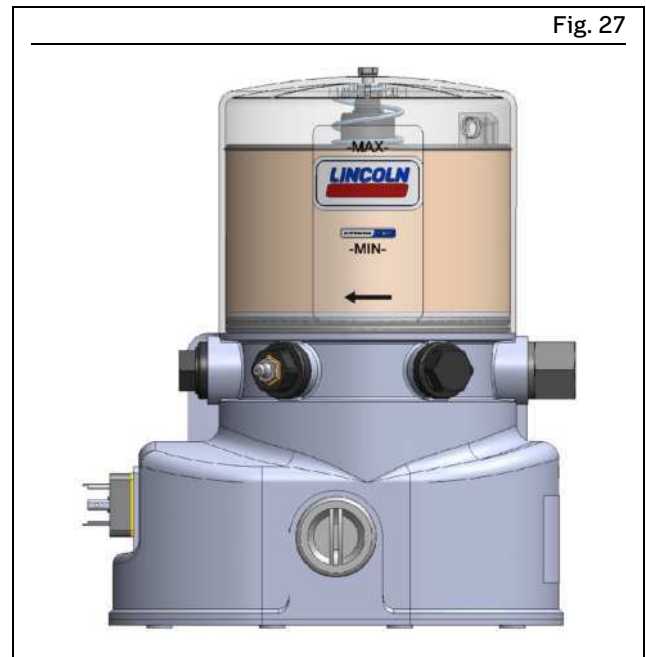

Pump filled and cable tie removed

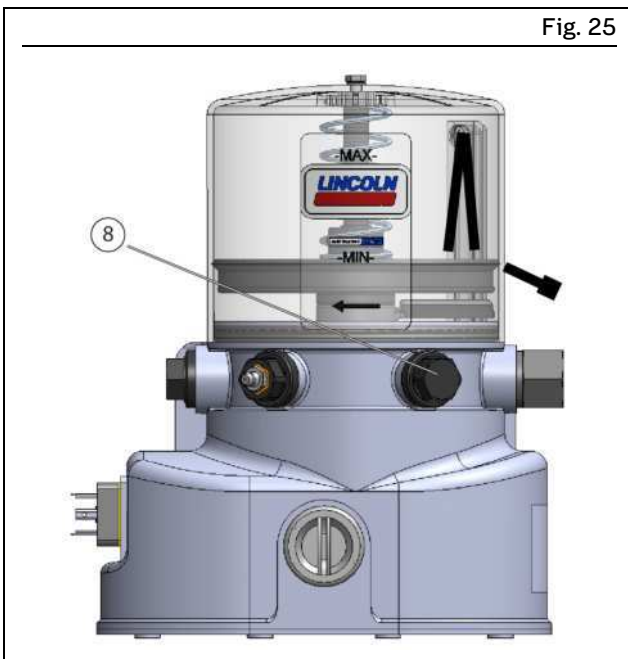

Unfilled pump with cable tie

6.10 Initial filling without a follower plate

NOTE

The pump comes partially filled when delivered from the factory. If specially agreed with the customer, the pump can also be delivered unfilled, and it must then be filled by following the instructions below.

NOTICE

Damage to the pump

When filling, make sure no contamination enters the reservoir.

Do not overfill the reservoir. Bear in mind the expansion of the lubricant due to increased temperature (important during storage or transportation of the pump, for example) and due to pressure relief after the filling procedure – this expansion could cause lubricant to block the reservoir ventilation point.

6.10.1 Filling via filler nipple

1. Place the fill connection of the filling pump on the R1/4 filler nipple (5).
2. Switch on the filling pump and fill the reservoir with lubricant up to just below the - MAX - mark.
3. Switch off the filling pump and remove the fill connection.
4. Remove any lubricant that came out and dispose of it in environmentally friendly manner.

6.10.2 Filling via fill connection

1. Unscrew the plug screw from the fill connection (8).
2. Screw in the connection of the cartridge.
3. Fill the reservoir with lubricant up to just below the - MAX- mark.
4. Unscrew and remove the connection of the cartridge and insert the plug screw into the fill connection.
5. Tightening torque = 10 Nm
6. Remove any lubricant that came out and dispose of it in environmentally friendly manner.

Fig. 28

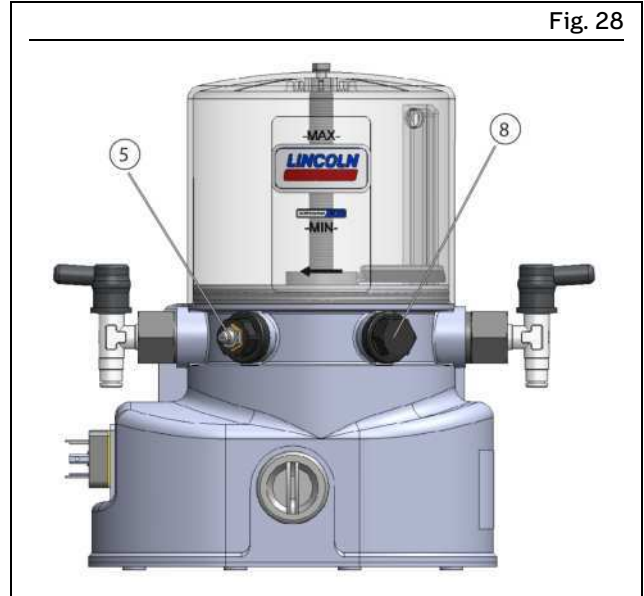

Initial filling of an empty pump without follower plate

6.11 Setting the lubrication time and pause time

6.11.1 Pumps without a control circuit board

NOTICE

Damage to the pump

The values specified in the "Technical data" section for permissible lubrication times and pause times must be complied with for pumps without control.

The lubrication times and pause times are set and modified by the external control to be provided by the operator.

6.11.2 Pumps with a control circuit board

NOTE

The newly set lubrication and pause times do not take effect until you switch the power supply to the pump off and back on again.

The lubrication times and pause times are set and modified by the internal control of the control circuit board.

The parameters are set using the two rotary switches on the control circuit board. (For values, see the "Technical data" section).

1. Remove the sealing cap (10) and the packing ring (14).
2. To set the pause time, turn the left-hand, blue rotary switch (20).
3. To set the lubrication time, turn the right-hand, red rotary switch (21).
4. Reinstall the sealing cap (10) and the packing ring (14).

Fig. 29

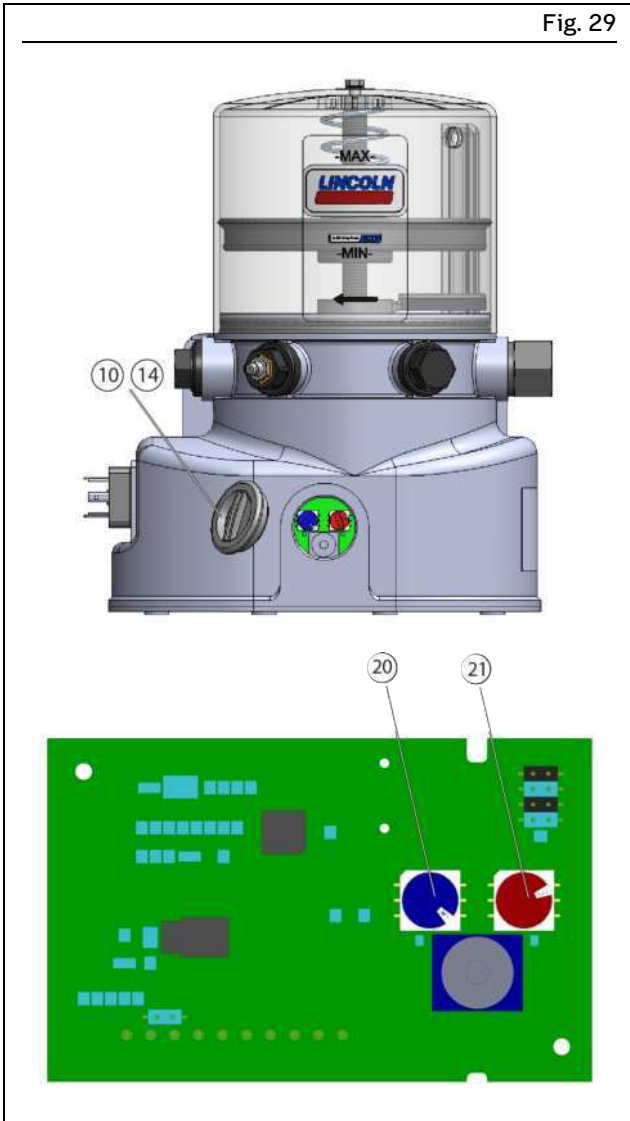

P502: Setting the lubrication time and pause time

6.12 Jumper settings

NOTICE

Damage to the pump

The jumper positions (31) on the control circuit board should not be modified. Modified jumper settings are not immediately obvious to other people and could therefore lead to incorrect settings of the lubrication and pause times on the rotary switches of the control circuit board.

Fig. 30

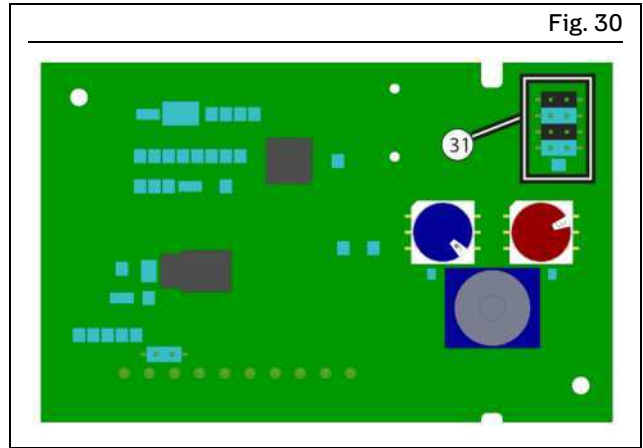

P502: setting jumpers for lubrication time and pause time

Table 11

Control circuit board	Pause time		Operating time		Jumper position
	4-60 min.	1-15 h	8-120 S	2-30 min.	
V10				X	min P h I S min
V20		X			
V11					min P h I S min
V21		X	X		
V12					min P h I S min
V22	X			X	
V13					min P h I S min
V23	X		X		

 = jumper set

NOTE

Pumps with V10, V11, V12, and V13 control circuit boards can still operate when the main machine/vehicle is not running because the terminals 15/30 are jumpered internally.

7 First start-up

7.1 General

NOTE

First start-up of the fully and correctly assembled pump is performed using the machine contact or vehicle driver switch. The pump begins with a pause time. Therefore, after connecting the pump and setting the required lubrication time and pause time, first a lubrication pulse should be triggered to check that the pump is connected correctly. In the case of pumps without control, the lubrication pulse is triggered by the PLC of the main machine.

7.2 Inspection before initial start-up

ATTENTION

Risk of damage to the machine

Fill the feed lines and bearing housings with lubricant to specification and lubricate the lubrication points by hand. Otherwise the bearing points may become damaged due to a lack of lubricant. Check the entire system for accordance with the intended purpose and the planning documentation. Ensure that all parameters, characteristic values and means of operation are present and have been correctly adjusted. If deviations are detected, they must be remedied without delay.

In order to warrant safety and function, a person assigned by the operator must carry out the following inspections. Immediately eliminate detected deficiencies. Deficiencies may be remedied by an authorized and qualified specialist only.

Table 1

7.3 Inspections before first start-up

YES NO

Electrical connection established correctly	<input type="checkbox"/>	<input type="checkbox"/>
Mechanical connection established correctly	<input type="checkbox"/>	<input type="checkbox"/>
The performance characteristics for the aforementioned connections match the specifications in the "Technical data"	<input type="checkbox"/>	<input type="checkbox"/>
All components such as lubrication lines and metering devices are correctly installed	<input type="checkbox"/>	<input type="checkbox"/>
Product is protected by a suitable pressure limiting valve	<input type="checkbox"/>	<input type="checkbox"/>
No apparent damage, contamination, or corrosion	<input type="checkbox"/>	<input type="checkbox"/>
Any dismantled protective and monitoring equipment is fully reinstalled and functional	<input type="checkbox"/>	<input type="checkbox"/>
All safety markings on the product are present and in proper condition	<input type="checkbox"/>	<input type="checkbox"/>

7.4 Inspections during first start-up

No unusual noises, vibrations, moisture accumulation, or odors present	<input type="checkbox"/>	<input type="checkbox"/>
No undesired discharge of lubricant (leakages) at connections	<input type="checkbox"/>	<input type="checkbox"/>
Lubricant is fed without bubbles	<input type="checkbox"/>	<input type="checkbox"/>
The bearings and friction points requiring lubrication receive the planned lubricant volume	<input type="checkbox"/>	<input type="checkbox"/>

7.5 Triggering additional lubrication

1. Remove the sealing cap (10) and the packing ring (14).
2. To trigger additional lubrication, press the pushbutton (12) on the control circuit board (for more than 2 seconds).

The pump starts a lubrication cycle. The duration of the lubrication cycle is determined by the value set on the control circuit board (see the Assembly section).

3. Reinstall the sealing cap (10) and the packing ring (14).

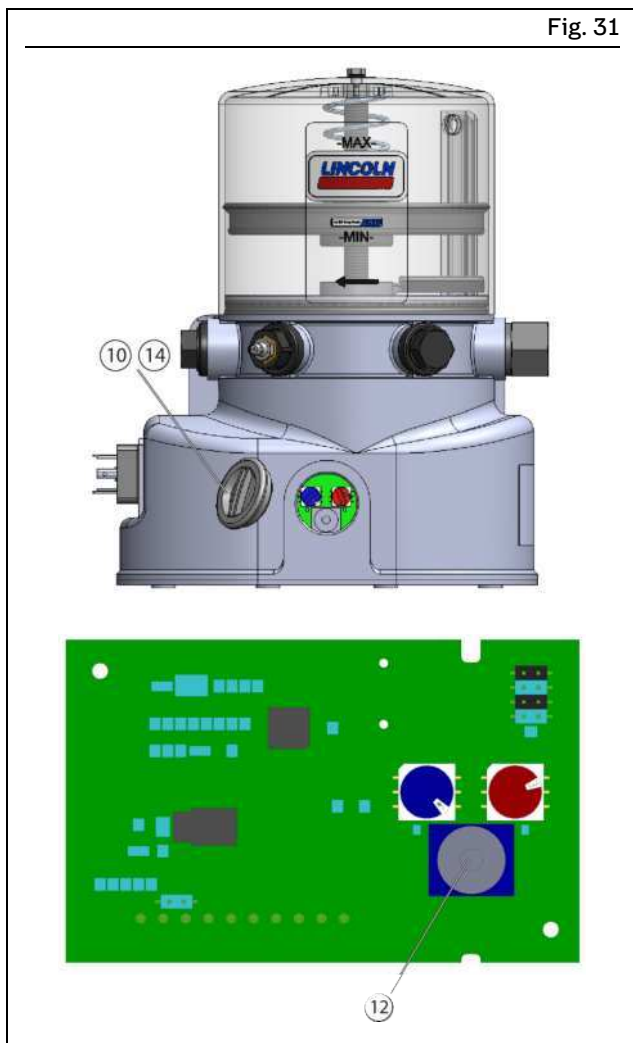

P502: Triggering additional lubrication

8 Operation

8.1 Operation

When correctly connected electrically and filled with lubricant, the pump is ready for operation. Start-up and shutdown are performed by the main machine or vehicle switching on and off, respectively.

8.2 Filling the reservoir during operation

8.2.1 Filling via filler nipple

1. Connect the filling connection to the filler nipple (5) and fill the reservoir up to just below the -MAX- mark.
2. Remove the filling connection again.

8.2.2 Filling via fill connection

1. Remove the plug screw (8) from the fill connection.
2. Screw in the connection of the cartridge.
3. Fill the reservoir up to just below the - MAX - mark.
4. Unscrew and remove the connection of the cartridge and insert the plug screw (8) into the fill connection.

Tightening torque = 10 Nm

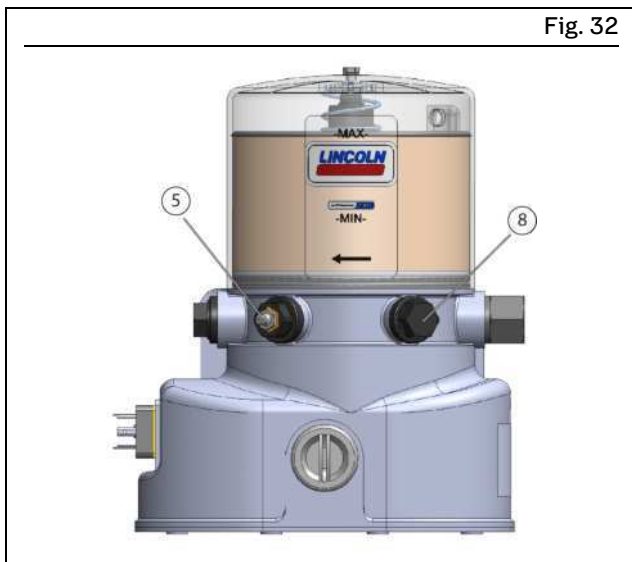

P502 with follower plate

9 Maintenance

Careful and regular maintenance is required in order to detect and remedy possible faults in time. The operator must always determine the specific intervals according to the operating conditions, review them regularly, and adjust them where necessary. If necessary, copy the table for regular maintenance activities.

Table 12		
Checklist: Maintenance activities		
Activity to be performed	YES	NO
Mechanical and electrical system connections established correctly	<input type="checkbox"/>	<input type="checkbox"/>
The performance characteristics for the aforementioned connections match the specifications in the "Technical data"	<input type="checkbox"/>	<input type="checkbox"/>
All components such as lubrication lines and metering devices are correctly installed	<input type="checkbox"/>	<input type="checkbox"/>
No apparent damage, contamination, or corrosion	<input type="checkbox"/>	<input type="checkbox"/>
Any dismantled protective and monitoring equipment is fully reinstalled and functional	<input type="checkbox"/>	<input type="checkbox"/>
All warning labels on the product are present and in proper condition	<input type="checkbox"/>	<input type="checkbox"/>
No unusual noises, vibrations, moisture accumulation, or odors present	<input type="checkbox"/>	<input type="checkbox"/>
No undesired discharge of lubricant (leakages) at connections	<input type="checkbox"/>	<input type="checkbox"/>
Lubricant is fed without bubbles	<input type="checkbox"/>	<input type="checkbox"/>
The bearings and friction points requiring lubrication receive the planned lubricant volume	<input type="checkbox"/>	<input type="checkbox"/>

10 Cleaning

10.1 Basics

Cleaning should be carried out in accordance with the operator's own company rules, and cleaning agents and devices and the personal protective equipment to be used should likewise be selected in accordance with those rules. Only cleaning agents compatible with the materials may be used for cleaning. Completely remove any cleaning agent residue left on the product and rinse with clear water. Unauthorized persons must be kept away. Use signage to indicate wet areas.

10.2 Interior cleaning

The interior normally does not need to be cleaned. The interior of the product must be cleaned if incorrect or contaminated lubricant accidentally enters the product. Please contact our Service department.

10.3 Exterior cleaning

Do not allow any cleaning fluid to enter the interior of the product during cleaning.

⚠ WARNING

Risk of fatal electric shock





 Cleaning work may only be performed on products that have been de-energized first. When cleaning electrical components, be mindful of the IP enclosure rating.

⚠ WARNING

Serious injury from contact with or inhalation of hazardous substances



 Wear personal protective equipment. Observe the safety data sheet (SDS) of the hazardous substance. Avoid contaminating other objects or the environment during cleaning.



11 Faults, causes, and remedies

11.1 Fault tables

NOTE

After resolving the following faults, the pump does not start automatically. Instead, it must be checked by triggering additional lubrication (see section 7.3). Please contact our Customer Service if you cannot determine or resolve the error.

Table 13

Fault table: pumps with and without control (the motor of the pump is running, but the pump does not pump anything)

Possible cause	Detectable	Remedy
Reservoir empty	<ul style="list-style-type: none"> • Fault code F1 • Visual inspection 	<ul style="list-style-type: none"> • Refill the reservoir
Air inclusion in the lubricant	<ul style="list-style-type: none"> • Bubbles in lubricant 	<ul style="list-style-type: none"> • Bleed the lubricant (let the pump run)
Suction bore of the pump element clogged	<ul style="list-style-type: none"> • After removing the pump element 	<ul style="list-style-type: none"> • Remove and clean the pump element
The piston of the pump element is worn	<ul style="list-style-type: none"> • Insufficient pressure build-up 	<ul style="list-style-type: none"> • Replace pump element
Defective pressure relief valve / fault at lubrication point	<ul style="list-style-type: none"> • Lubricant leaking from the pressure limiting valve 	<ul style="list-style-type: none"> • Replace pressure limiting valve. Check the lubrication point and remedy any fault
Reservoir ventilation clogged	<ul style="list-style-type: none"> • Visual inspection to check if there is lubricant in the reservoir ventilation 	<ul style="list-style-type: none"> • Clean the reservoir ventilation and find out the cause
Follower plate is stuck (pumps with a follower plate)	<ul style="list-style-type: none"> • Visual inspection 	<ul style="list-style-type: none"> • Determine and resolve the cause

Table 14

Fault table: pumps with control (the motor of the pump is not running)

Possible cause	Detectable	Remedy
Fault in the main machine or vehicle	<ul style="list-style-type: none"> • See the manual for the machine/vehicle 	<ul style="list-style-type: none"> • See the manual for the machine/vehicle
Electrical fault	<ul style="list-style-type: none"> • Stirring paddle does not rotate • By fault codes of the LEDs on the control circuit board • Fault signaled by an external device 	<ul style="list-style-type: none"> • Check the wiring, control circuit board, fuses, motor, and power supply. • If necessary, carry out a fault analysis of the machine/vehicle
Mechanical fault	<ul style="list-style-type: none"> • Stirring paddle does not rotate 	<ul style="list-style-type: none"> • Replace the defective motor
Rotary switch on the control circuit board in 0 position	<ul style="list-style-type: none"> • By fault code F 2 on the LEDs on the control circuit board 	<ul style="list-style-type: none"> • Turn the rotary switch to the correct position.
Fault signal for control circuit board	<ul style="list-style-type: none"> • By a fault code of the LEDs on the control circuit board 	<ul style="list-style-type: none"> • Check the line and replace it if necessary
Short circuit on pushbutton or on the line to the external pushbutton	<ul style="list-style-type: none"> • By fault code F 3 on the LEDs on the control circuit board 	<ul style="list-style-type: none"> • If there is a short circuit on the pushbutton of the control circuit board, replace the control circuit board. In the case of an external pushbutton: check the line and replace the pushbutton if necessary

Table 15

Fault table: pumps without control (the motor of the pump is not running)

Possible cause	Detectable	Remedy
The pump is in pause time	<ul style="list-style-type: none"> No noise from the pump 	<ul style="list-style-type: none"> It may be necessary to check the functioning of the pump by triggering additional lubrication
Fault in the main machine, vehicle, or external control	<ul style="list-style-type: none"> Bubbles in lubricant 	<ul style="list-style-type: none"> Check the wiring Resolve the fault according to the instructions in the manual for the machine, vehicle, or external control
Electrical fault of the pump	<ul style="list-style-type: none"> After removing the pump element 	<ul style="list-style-type: none"> Have an electrician check/repair the pump
Mechanical fault	<ul style="list-style-type: none"> Insufficient pressure build-up 	<ul style="list-style-type: none"> Check if the piston stayed in the pump after a pump element was replaced

11.2 Display of fault codes

NOTE

After resolving the following faults, the pump does not start automatically. Instead, it must be checked by triggering additional lubrication (see section 7.3). Please contact our Customer Service if you cannot determine or resolve the error.

On pumps with a control circuit board, operational and fault states are indicated by different patterns displayed on the green and red LEDs on the control circuit board. One display cycle takes 6 seconds. After that, the display cycle starts again. The following displays are possible.

Table 16

No error

The green LED shows a steady light

	1st second				2nd second				3rd second				>>>>>>				6th second			
Green	★	★	★	★	★	★	★	★	★	★	★	★	★	★	★	★	★	★	★	★
Red																				

Table 17

Error F1

The green LED shows a steady light. The red LED flashes every 6 seconds for 0.25 seconds

	1st second				2nd second				3rd second				>>>>>>				7 second			
Green	★	★	★	★	★	★	★	★	★	★	★	★	★	★	★	★	★	★	★	★
Red	★																★			

Table 18

Error F2

One or both rotary switches on the control circuit board are in the “0” position. The green LED shows a steady light. During the first 2 seconds, the red LED flashes for 0.25 seconds, followed by a pause of 4 seconds.

	1st second				2nd second				3rd second				>>>>>>				7 second			
Green	★	★	★	★	★	★	★	★	★	★	★	★	★	★	★	★	★	★	★	★
Red	★				★												★			

Table 19

Error F3

Button Z (additional lubrication) is defective, permanently pressed, or there is a short circuit. The green LED shows a steady light. During the first 3 seconds, the red LED flashes for 0.25 seconds, followed by a pause of 3 seconds.

	1st second				2nd second				3rd second				>>>>>>				7 second			
Green	★	★	★	★	★	★	★	★	★	★	★	★	★	★	★	★	★	★	★	★
Red	★				★				★								★			

Table 20

Error F4

Undervoltage (the green and red LEDs flash at one-second intervals)

	1st second				2nd second				3rd second				4 second				5 second			
Green	★	★	★	★					★	★	★	★					★	★	★	★
Red	★	★	★	★					★	★	★	★					★	★	★	★

12 Repairs

⚠ WARNING



Risk of injury

At a minimum, the following safety measures must be taken before any repairs:



- Unauthorized persons must be kept away
- Mark and secure the work area



- Depressurize the product
- Isolate the product, and lock and tag it out
- Check to ensure live voltage is no longer present
- Ground and short-circuit the product
- Cover any adjacent live parts.

12.1 Replacing the control circuit board

NOTICE

Damage to the pump

Mark the detached connectors of the control circuit board to prevent them from being mixed up or twisted.

- Switch off the pump and isolate it from the power supply.
 - Remove the screws (19) from the housing cover.
 - Remove the housing cover (16) and seal.
 - Detach the two connectors (17) and remove the old control circuit board (11).
 - Check the lubrication time and pause time of the new control circuit board and, if not correct, set them correctly (see the relevant section of these instructions).
 - Check the positions of the jumpers on the new circuit board and, if not correct, adjust them to match the jumper positions on the circuit board being replaced.
 - Connect the new control circuit board to the two connectors (17).
 - Insert the control circuit board into the two fixations (18) on the housing cover (16).
 - Install the housing cover and seal.
 - Fasten the screws (19) on the housing cover.
- Tightening torque for housing cover = 0.8 Nm

Fig. 33

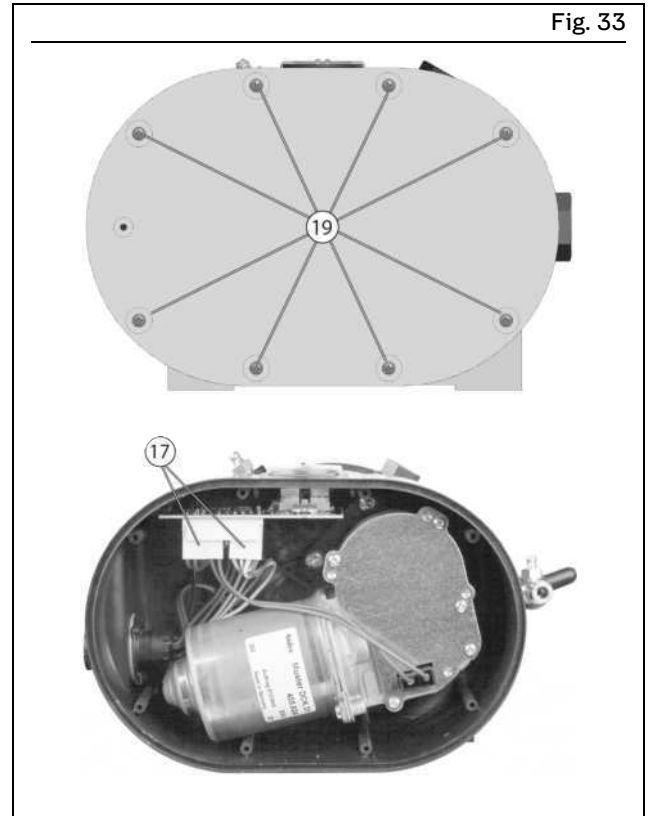

Replacing the control circuit board

Fig. 34

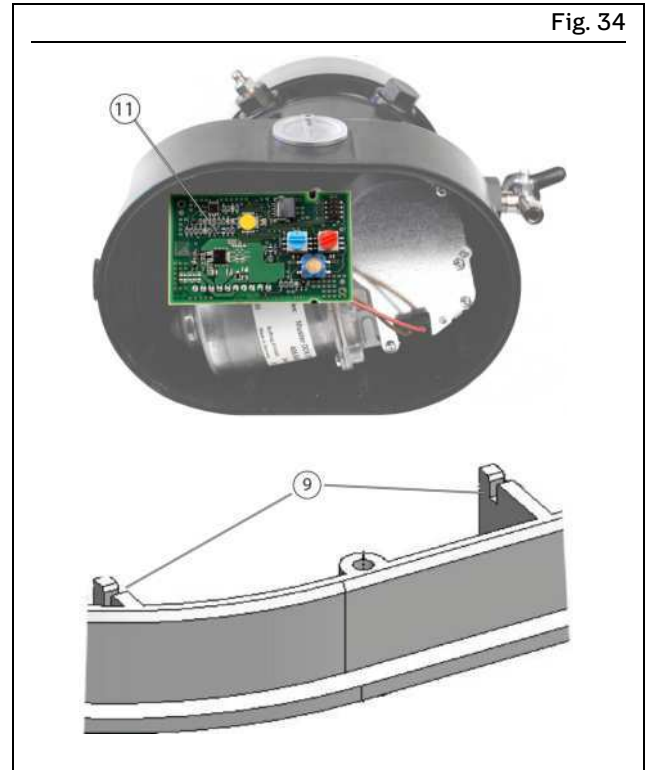

Replacing the control circuit board

12.2 Checks after replacing the control circuit board

After replacing the control circuit board, an electrical inspection in accordance with DIN EN 60204-1 must be performed in the following order:

12.2.1 Visual inspection

Properly install the housing cover. No damage noticeable on the pump.

12.2.2 Electrical safety check

Use measuring equipment in accordance with EN 61557 for the specified electrical inspection and testing.

- Check the protective earthing system for continuity.

12.2.3 Electrical functional test

Carry out the electrical functional test in accordance with these instructions.

12.2.4 Archiving

The scope and results of the inspection after replacement of the control circuit board must be recorded in writing and given to the party responsible for operation of the machine, for archiving.

12.3 Replacing the pressure limiting valves and pump elements

- Switch off the pump and isolate it from the power supply.
- Remove the pressure limiting valve (13). You may still need to detach the feed lines first.
- Unscrew the pressure limiting valve (13) out of the pump element.
- Insert a new pump element (9) and a new packing ring.

Tightening torque for pump element = 20 Nm

- Install the pressure limiting valve.

Tightening torque for pressure limiting valve = 8 Nm

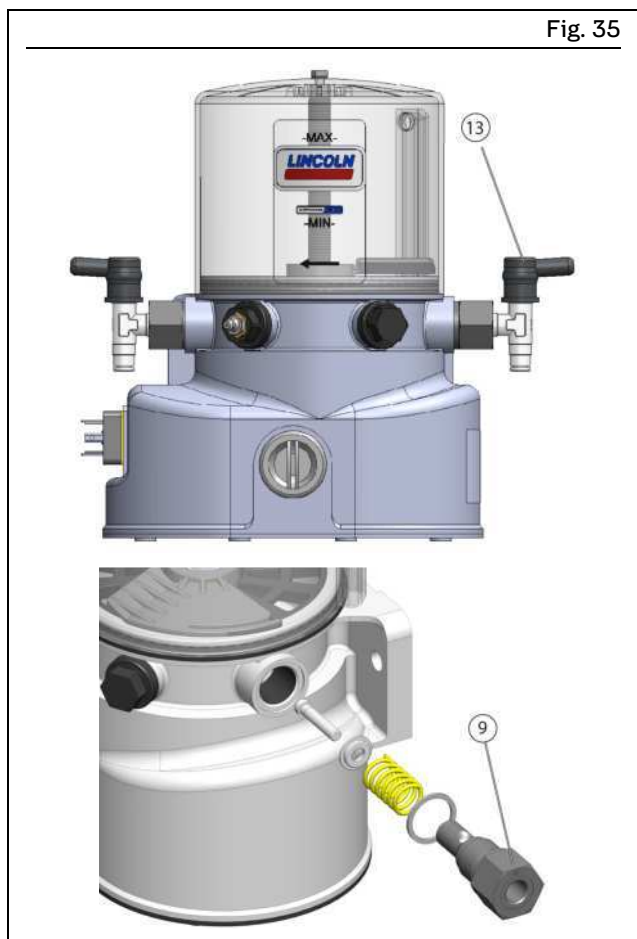

Replacement of pump element and pressure limiting valve

12.5 Replacing a reservoir with a follower plate

- Switch off the pump and isolate it from the power supply. If necessary, uninstall it and transport it into a workshop.
 - Undo and remove the screw (22).
 - Pull the reservoir up to remove it from the pump.
 - If any lubricant comes out, dispose of it in an environmentally friendly manner.
 - Detach the spring (25) at the top of the reservoir and keep it for later use.
 - Check the follower plate (2) and seal for damage. If damaged, replace these parts too.
 - Remove the two O-rings (23) from their grooves in the pump housing and dispose of them.
 - Lightly coat new O-rings (23) with oil and insert them in the corresponding grooves on the pump housing.
 - Reinstall the spring (25) in the matching lug at the top of the new reservoir.
 - Place the new reservoir (1) on the pump. Be sure to guide the spring (25) over the reservoir axle (24).
 - Press the reservoir all the way down, over the two O-rings (23).
 - Fasten the reservoir (1) on the reservoir axis (24) with a new screw (22) and washer.
- Tightening torque = 2+1 Nm**
- Fill the reservoir with lubricant again (see the relevant section of these instructions).
 - Reinstall the pump at the place of use and connect it electrically.

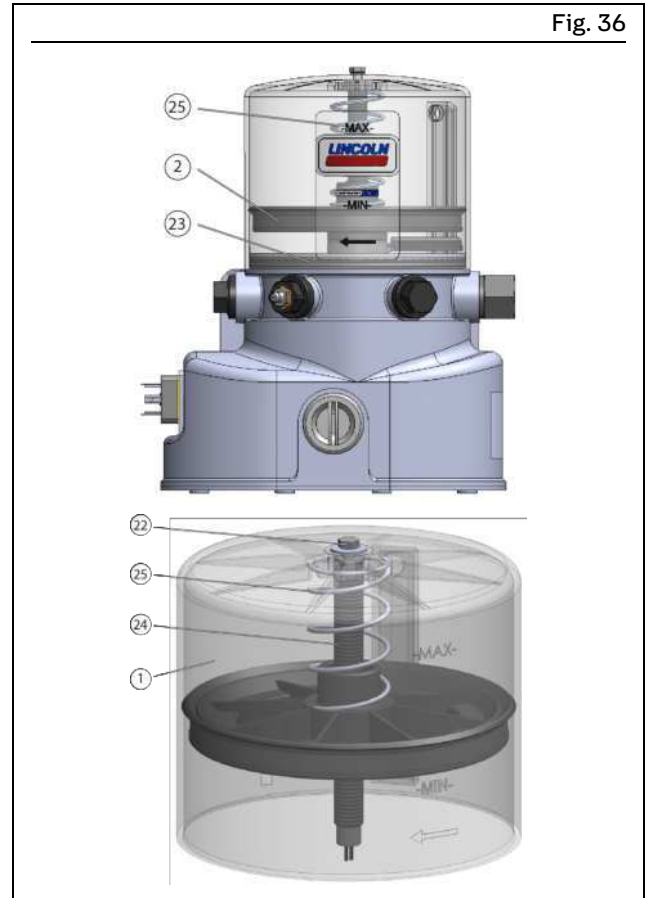

Replacing a reservoir with a follower plate (XLF)

12.6 Replacing the follower plate

- Switch off the pump and isolate it from the power supply. If necessary, uninstall it and transport it into the workshop.
 - Undo and remove the screw (22).
 - Pull the reservoir (1) up to remove it from the pump.
 - If any lubricant comes out, dispose of it in an environmentally friendly manner.
 - Detach the spring (25) at the top of the reservoir and dispose of it in an environmentally friendly manner.
 - Remove the follower plate (2) and dispose of it in an environmentally friendly manner.
 - Remove the two O-rings (23) from their grooves in the pump housing and dispose of them.
 - Lightly coat new O-rings (23) with oil and insert them in the corresponding grooves on the pump housing.
 - Slide a new follower plate down over the reservoir axle.
 - Reinstall the spring (25) in the matching lug at the top of the reservoir.
 - Place the reservoir (1) on the pump. Be sure to guide the spring (25) over the reservoir axle (24).
 - Press the reservoir all the way down, over the two O-rings (23).
 - Fasten the reservoir (1) on the reservoir axis (24) with a new screw (22) and washer.
- Tightening torque = 2+1 Nm**
- Fill the reservoir with lubricant again (see the relevant section of these instructions).
 - Reinstall the pump at the place of use and connect it electrically.

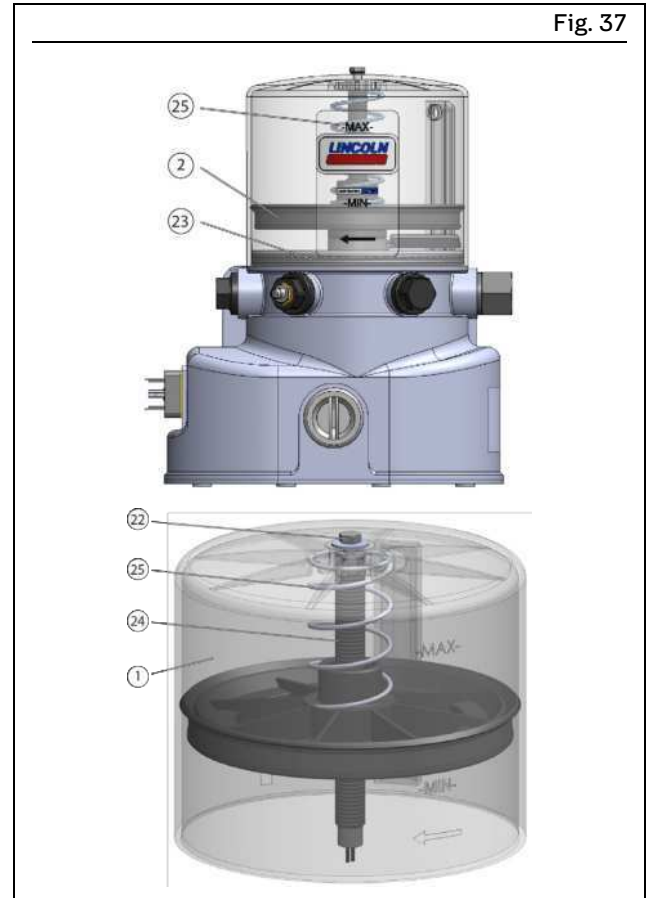

Replacing the follower plate

12.7 Replacing a reservoir without a follower plate

- Switch off the pump and isolate it from the power supply. If necessary, uninstall it and transport it into the workshop.
- Undo and remove the screw (22).
- Pull the reservoir (1) up to remove it from the pump.
- If any lubricant comes out, dispose of it in an environmentally friendly manner.
- Remove the two O-rings (23) from their grooves in the pump housing.
- Lightly coat new O-rings (23) with oil and insert them in the corresponding grooves on the pump housing.
- Place the new reservoir (1) on the pump.
- Press the reservoir all the way down, over the two O-rings (23).
- Fasten the reservoir (1) on the reservoir axis (24) with a new screw (22) and washer.

Tightening torque = 2+1 Nm

- Fill the reservoir with lubricant again (see the relevant section of these instructions).
- Reinstall the pump at the place of use and connect it electrically.

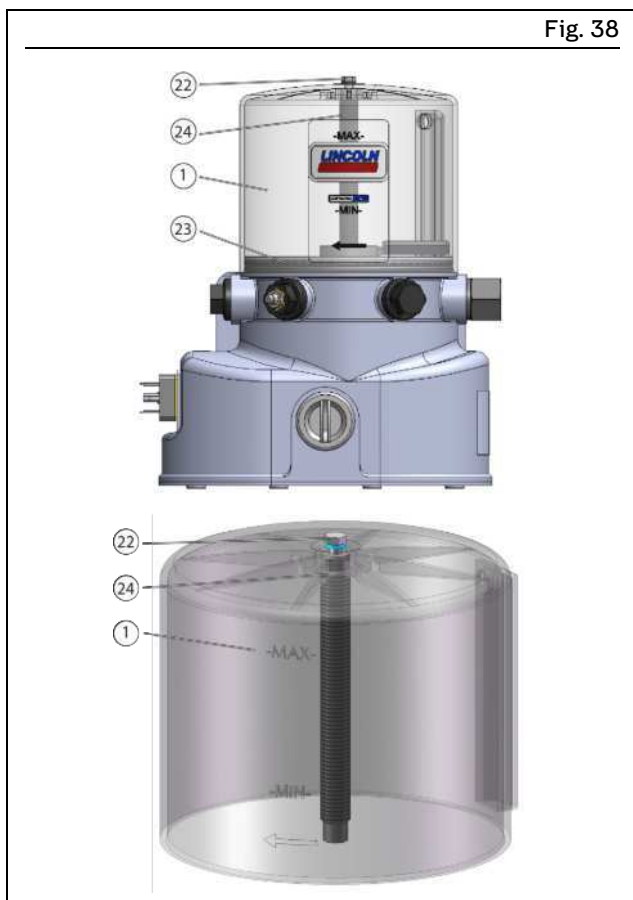

Replacing a reservoir without a follower plate

13 Shutdown, disposal

13.1 Temporary shutdown

Temporary shutdowns should be done by a course of action to be defined by the operator.

13.2 Permanent shutdown, disassembly

Permanent shutdown and disassembly of the product must be planned properly by the operator and conducted in compliance with all applicable laws and regulations.

13.3 Disposal

The waste producer/operator must dispose of the various types of waste in accordance with the applicable laws and regulations of the country in question.

14 Spare parts

Spare parts may be used exclusively for replacement of identical defective parts. Modifications with spare parts on existing products are not allowed.

14.1 Pump elements

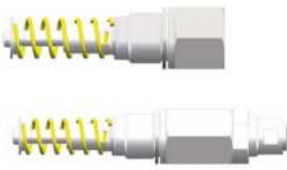
Designation	Pcs.	Item number	Item number	Figure
		C3 design	C5-M design	
Pump element L5 incl. packing ring	1	600-78018-1	Not available	
Pump element K5 incl. packing ring	1	600-26875-2	600-29303-1	
Pump element K6 incl. packing ring	1	600-26876-2	600-29304-1	
Pump element K7 incl. packing ring	1	600-26877-2	600-29305-1	
Pump element KR incl. packing ring	1	655-28716-1	Not available	
Pump element B7 incl. packing ring	1	600-29185-1	Not available	
Pump element C7 incl. packing ring	1	655-28750-1	Not available	

14.2 Pressure limiting valve

Designation	Pcs.	Item number	Figure
Pressure limiting valve (270 bar Ø 6 mm)	1	624-28892-1	

14.3 Adapter with lubricant nipple

Designation	Pcs.	Item number	Figure
Adapter with grease fitting R 1/4"	1	519-33955-1	

14.4 Spare part kit for replacing the reservoir

Designation	Pcs.	Item number	Figure
Spare part kit for replacing the reservoir	1	558-33908-1	
Comprising:			
Reservoir P502	1		
Logo	1		
O-rings	2		
Seal for the reservoir screw	1		
Reservoir screw	1		

14.5 Spare part kit for replacing the follower plate

Designation	Pcs.	Item number	Figure
Spare part kit for replacing the follower plate	1	558-85011-1	
Comprising:	1		
Follower piston with packing ring	1		
Spring	2		
O-rings (O-rings: see spare part kit for replacing the reservoir)			

14.6 Spare part kit for replacing the control circuit board

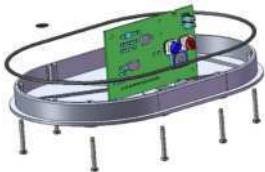
Designation	Pcs.	Item number	Figure
Spare part kit for replacing the control circuit board	1	558-34877-5	
Comprising:			
Control circuit board 12/24 V DC	1		
Housing cover	1		
Seal for housing cover	1		
Screws for housing cover	1		
Diaphragm for housing cover	1		

14.7 Spare part kit for replacing the screw cap

Designation	Pcs.	Item number	Figure
Spare part kit for replacing the screw cap	1	558-34877-6	
Comprising:			
Screw cap	1		
O-ring	1		

15 Appendix

15.1 Cable colors in accordance with IEC 60757

Table 21

Cable colors in accordance with IEC 60757

Abbreviation	Color	Abbreviation	Color	Abbreviation	Color	Abbreviation	Color
BK	Black	GN	Green	WH	White	PK	Pink
BN	Brown	YE	Yellow	OG	Orange	TQ	Turquoise
BU	Blue	RD	Red	VT	Violet	GY	Gray
GNYE	Green/Yellow	RDWH	Red/White	GD	Gold	SR	Silver

Not all cable colors need to be used in the terminal diagrams.

15.1.1 Recommended contact protection for switching inductive loads

Fig. 39

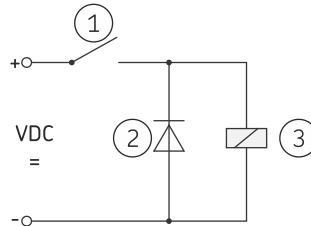

Contact protection

- 1 Contact of the low-level signal
- 2 Interference suppression diode (free-wheeling diode)
- 3 Load

When switching inductive loads with direct voltage, the operator should provide the contact protection measure shown in Figure 39 to protect the contacts of the low-level signal.

15.1.2 Wire assignment of the connector plugs

Wire assignment of connection A1 / X1

M12 connector, DIN EN 61076-2-101

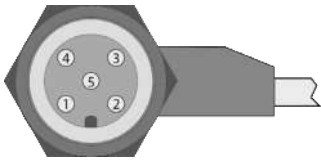

Pin 1	Pin 2	Pin 3	Pin 4	Pin 5	Pin 6	Pin 7
BN	----	BU	----	GN/YE	----	----
(M+)	----	(M-)	----	PE	----	----

Wire assignment of connection A2 / X2

Rectangular connector, DIN EN 175301-803

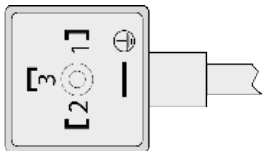

Pin 1	Pin 2	Pin 3	Pin 4	Pin 5	Pin 6	Pin 7
RD	BN	BK	GN/YE	----	----	----
(-)	(Z)	(+)	PE	----	----	----

Wire assignment of connection A1 / X1

Rectangular connector, DIN EN 175301-803

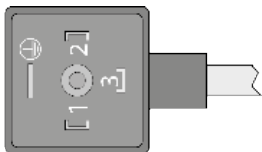

Pin 1	Pin 2	Pin 3	Pin 4	Pin 5	Pin 6	Pin 7
RD	BN	BK	GN/YE	----	----	----
(+30)	(-31)	(+15)	PE	----	----	----

Wire assignment of connection A1 / X1

Bayonet connector, 4/4-pin, ISO 15170-1

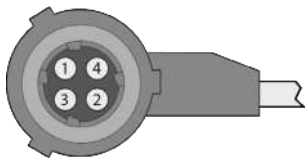

Pin 1	Pin 2	Pin 3	Pin 4	Pin 5	Pin 6	Pin 7
BK	BN	WH	YE	----	----	----
(M+)	(M-)	(LL)	(LL)	----	----	----

Wire assignment of connection A1 / X1

Bayonet connector, 7/5-pin and 7/6-pin, ISO 15170-1

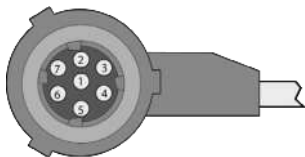

Pin 1	Pin 2	Pin 3	Pin 4	Pin 5	Pin 6	Pin 7
RD	BN	BK	WH	YE	BU	----
(+30)	(-31)	(+15)	(Z)	Signal	(LL)	----

15.2 Assignment of the terminal diagrams to the pump

The circuit diagrams are assigned to a specific pump on the basis of the following details in the type identification code.

- Position 4: Power supply voltage
- Position 5: Electrical connection
- Position 6: Connection type
- Position 8: Control circuit board

If the specifications in the type identification code match the specifications on the circuit diagram, that circuit diagram applies. The actual type identification code of the pump can be found on the type plate on the pump.

NOTE

Regarding pos. 5

Position 5 specifies the number of electrical connections on the pump.

It should be interpreted as follows:

1A = 1 connection on the pump

2A = 2 connections on the pump

To minimize the number of terminal diagrams, the diagrams always show the maximum possible number of electrical connections (pos. 5) for each connection type (pos.6). This means, for example, that if the pump has only one electrical connection (1A), the connection X2.2 on the connection diagram should be ignored.

Regarding pos. 6

Position 6 specifies the type of electrical connection on the pump.

It should be interpreted as follows:

1 = rectangular connector | 2 = M12 connector | 5 = bayonet connector 4/2-pin | 7 = bayonet connector 7/6-pin | 3, 4, and 6 = not assigned

Table 23

Assignment of the terminal diagrams to the pump

Details in the type identification code

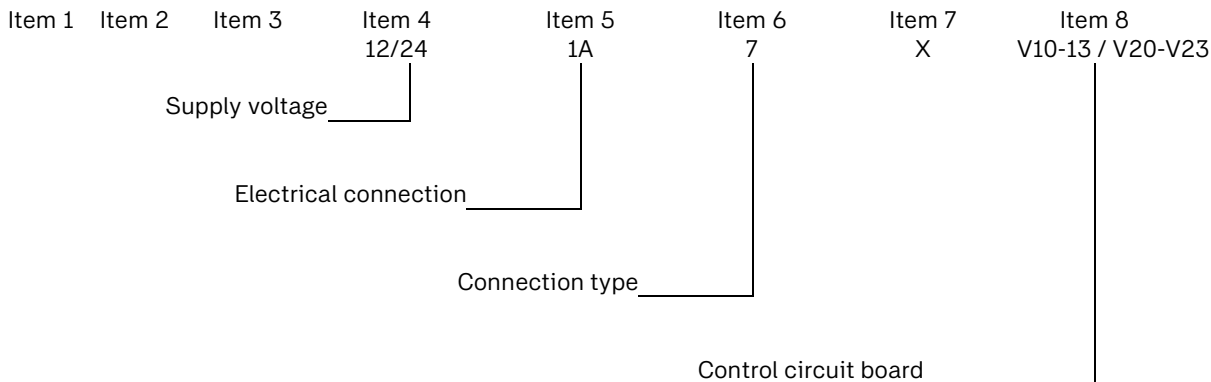

15.3 Terminal diagram 12 /24 V DC with bayonet connector and control circuit board V20

Table 24

Terminal diagram valid for pumps with the following equipment features

P502-XXXX-XXX-12-1A7-XX-V20
 P502-XXXX-XXX-24-1A7-XX-V20

Fig. 40

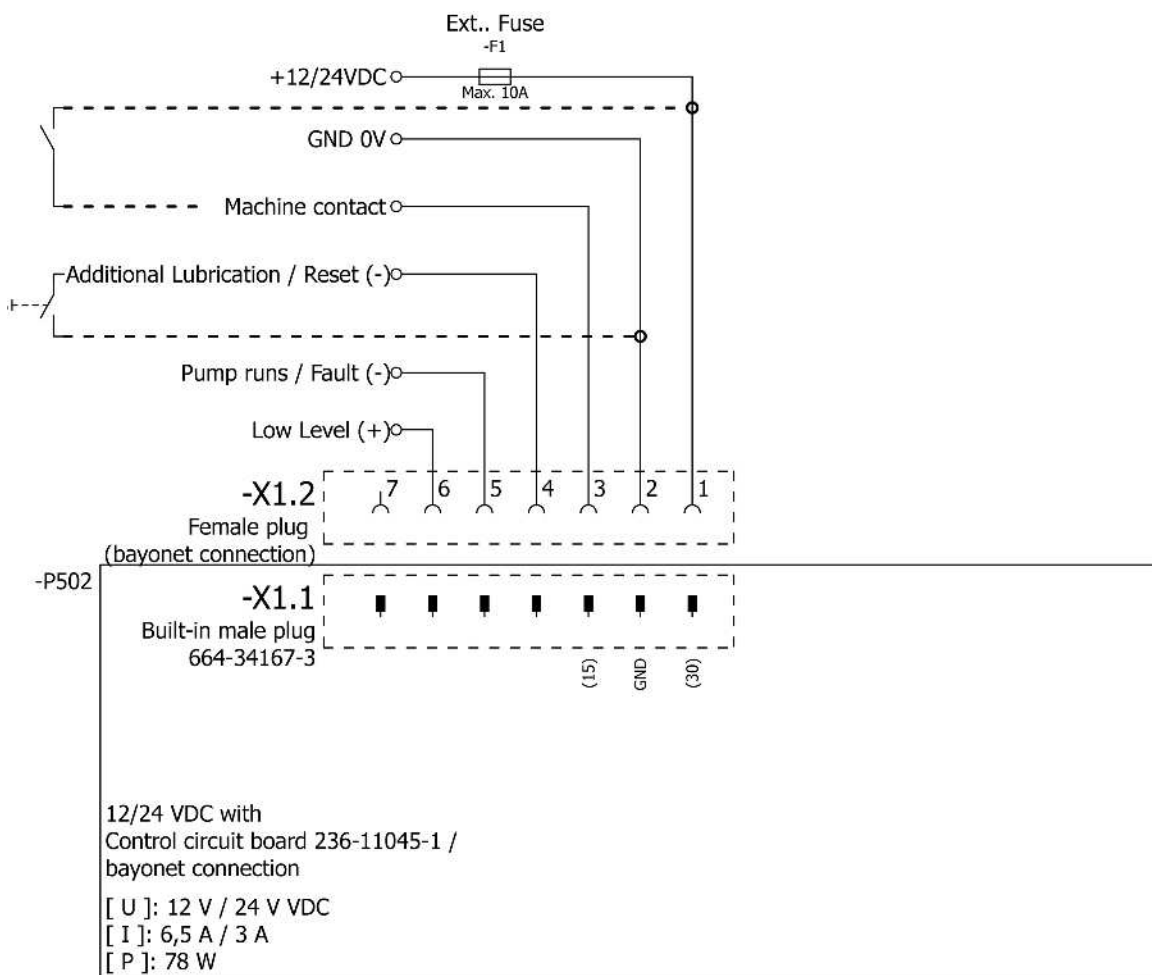

Terminal diagram 12 / 24 V DC with bayonet connector and control circuit board V20

15.4 Terminal diagram 12 /24 V DC with bayonet connector and control circuit board V10

Table 25

Terminal diagram valid for pumps with the following equipment features

P502-XXXX-XXX-12-1A7-XX-V10
 P502-XXXX-XXX-24-1A7-XX-V10

Fig. 41

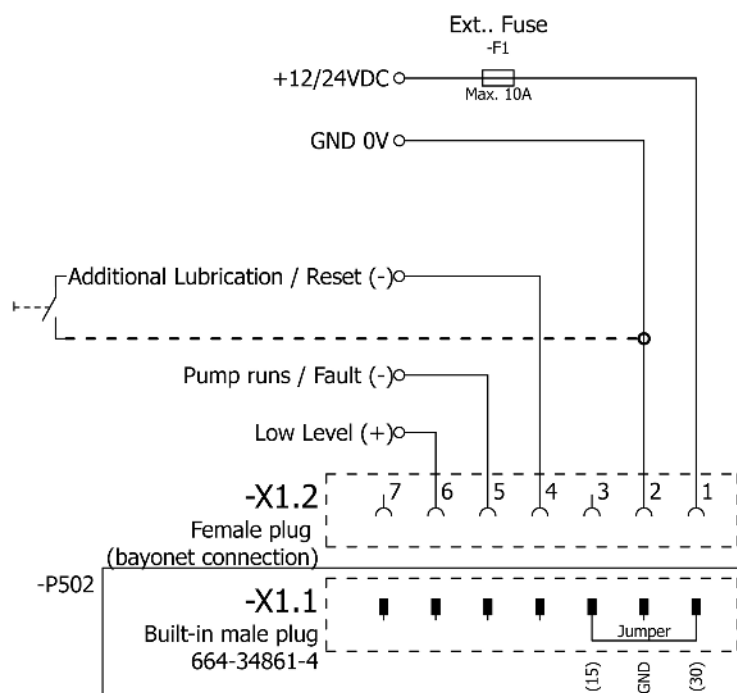

12/24 VDC with
 Control circuit board 236-11045-1 / bayonet connection
 (jumpered)

[U]: 12 V / 24 V VDC
 [I]: 6,5 A / 3 A
 [P]: 78 W

Terminal diagram 12 / 24 V DC with bayonet connector and control circuit board V10

15.5 Terminal diagram 12 /24 V DC with rectangular connector and control circuit board V20

Table 26

Terminal diagram valid for pumps with the following equipment features

- P502-XXXX-XXX-12-2A1-XX-V20
- P502-XXXX-XXX-24-2A1-XX-V20

Fig. 42

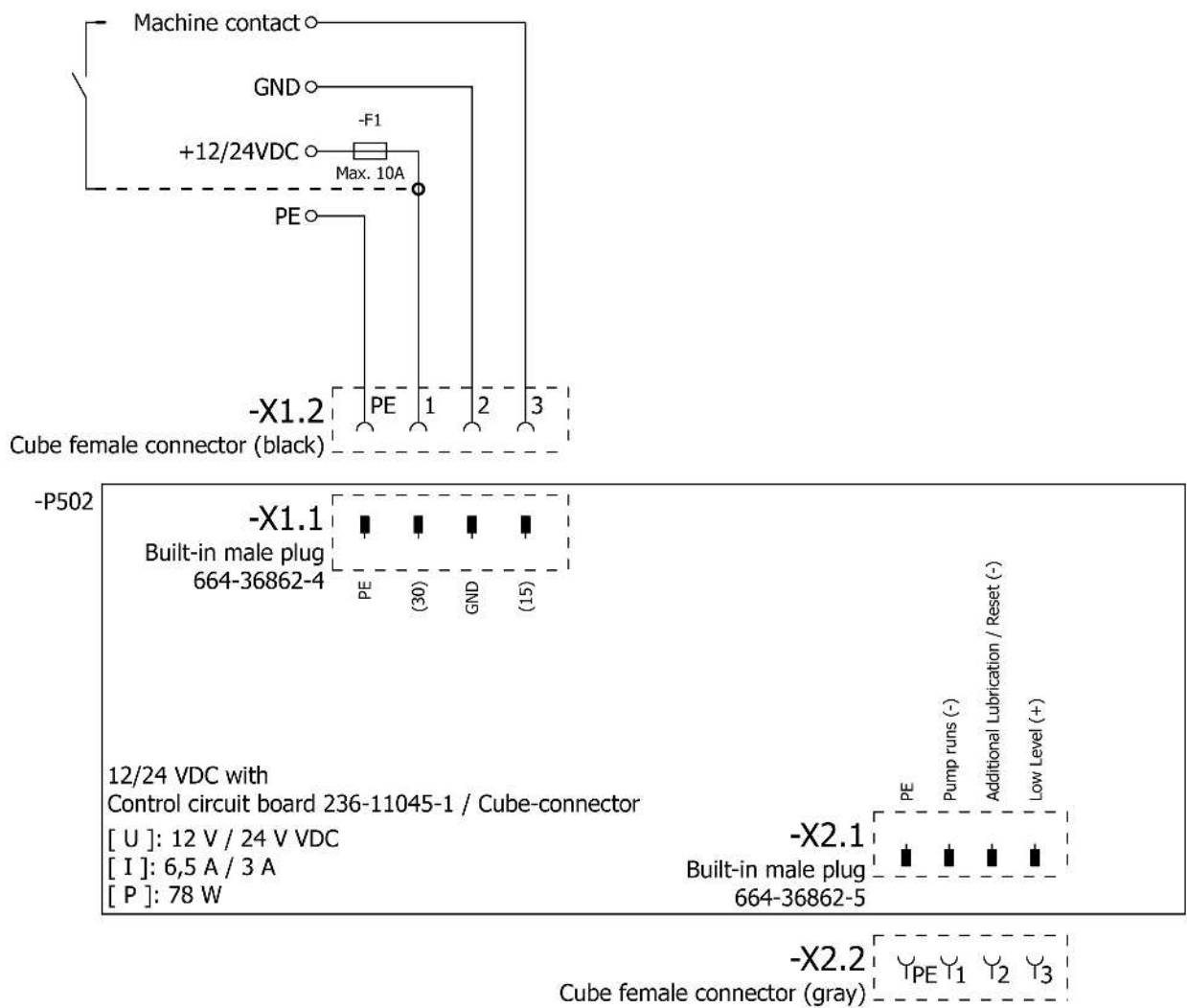

Terminal diagram 12 / 24 V DC with rectangular connector and control circuit board V20

15.6 Terminal diagram 12 /24 V DC with rectangular connector and control circuit board V10

Table 27

Terminal diagram valid for pumps with the following equipment features

P502-XXXX-XXX-12-2A1-XX-V10
 P502-XXXX-XXX-24-2A1-XX-V10

Fig. 43

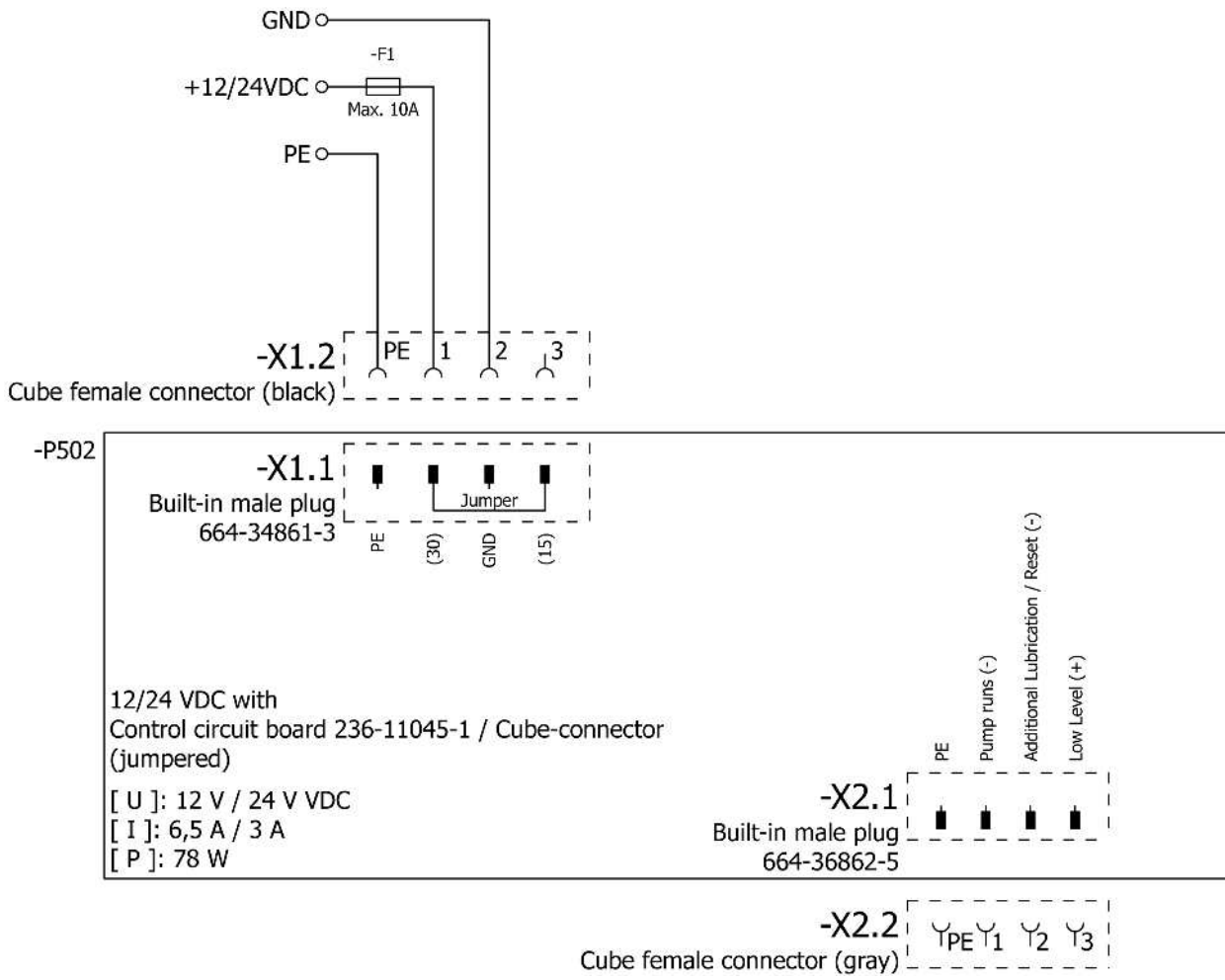

Terminal diagram 12 / 24 V DC with rectangular connector and control circuit board V10

15.7 Terminal diagram 24 V DC with M12 connector and control circuit board V20

Table 28

Terminal diagram valid for pumps with the following equipment features

P502-XXXX-XXX-24-2A2-XX-V20

Fig. 44

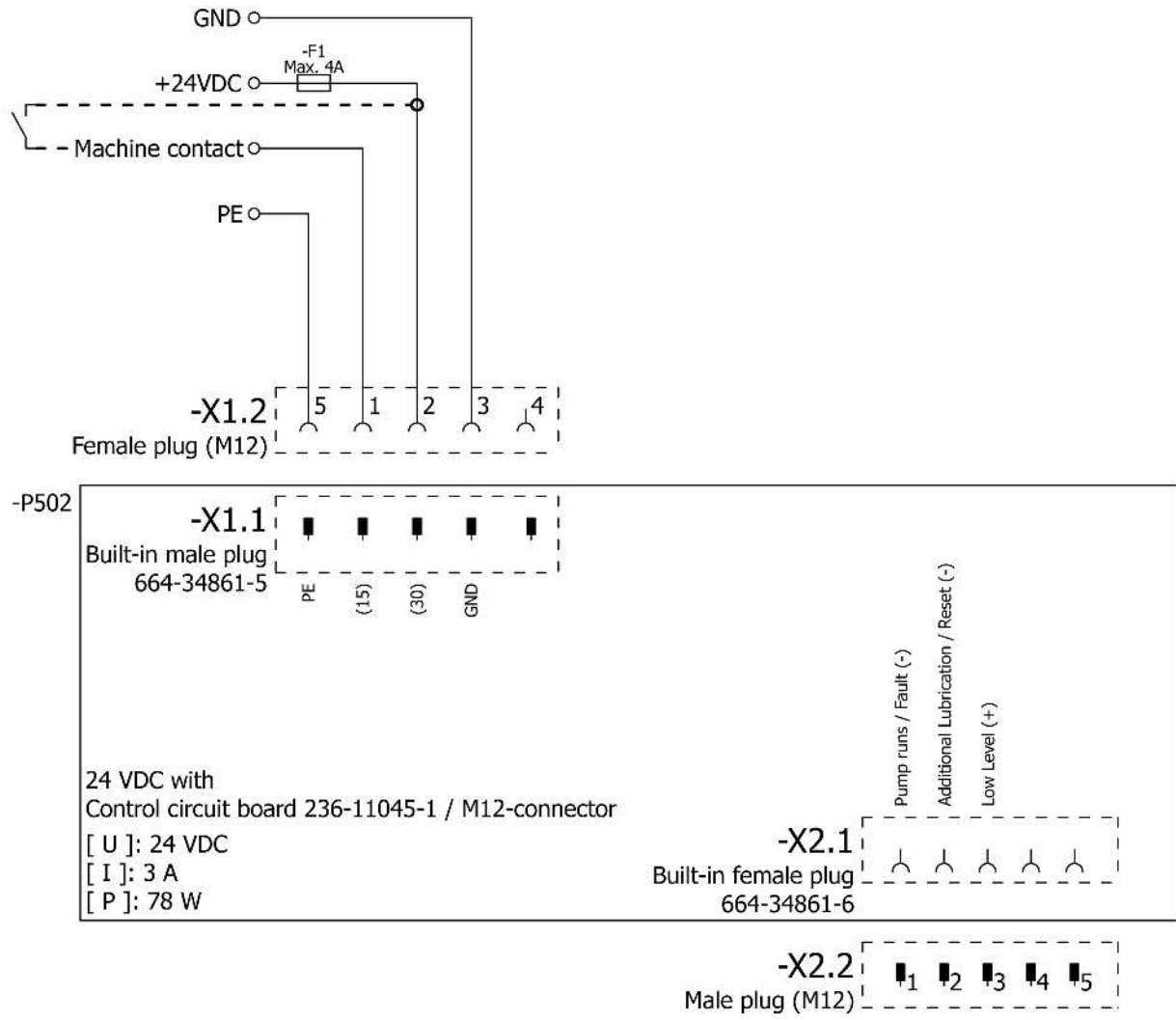

Terminal diagram 24 V DC with M12 connector and control circuit board V20

15.8 Terminal diagram 24 V DC with M12 connector without control circuit board

Table 29

Terminal diagram valid for pumps with the following equipment features

P502-XXXX-XXX-24-1A2-XX-

Fig. 45

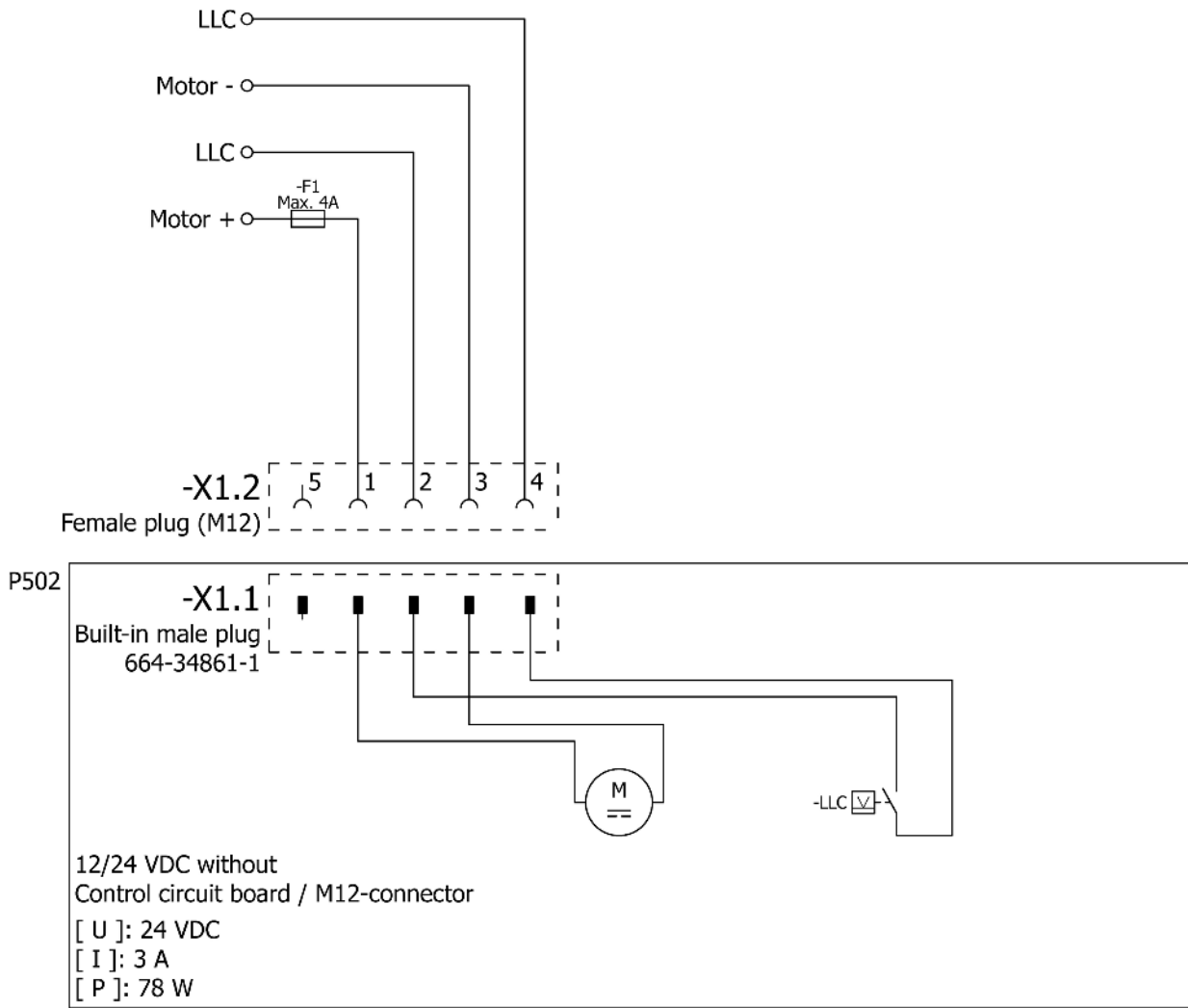

Terminal diagram 24 V DC with M12 connector without control circuit board

15.9 Terminal diagram 12 /24 V DC with rectangular connector without control circuit board

Table 30

Terminal diagram valid for pumps with the following equipment features

P502-XXXX-XXX-12-1A1-XX- P502-XXXX-XXX-24-2A1-XX-
 P502-XXXX-XXX-12-2A1-XX- P502-XXXX-XXX-24-2A1-XX-

Fig. 46

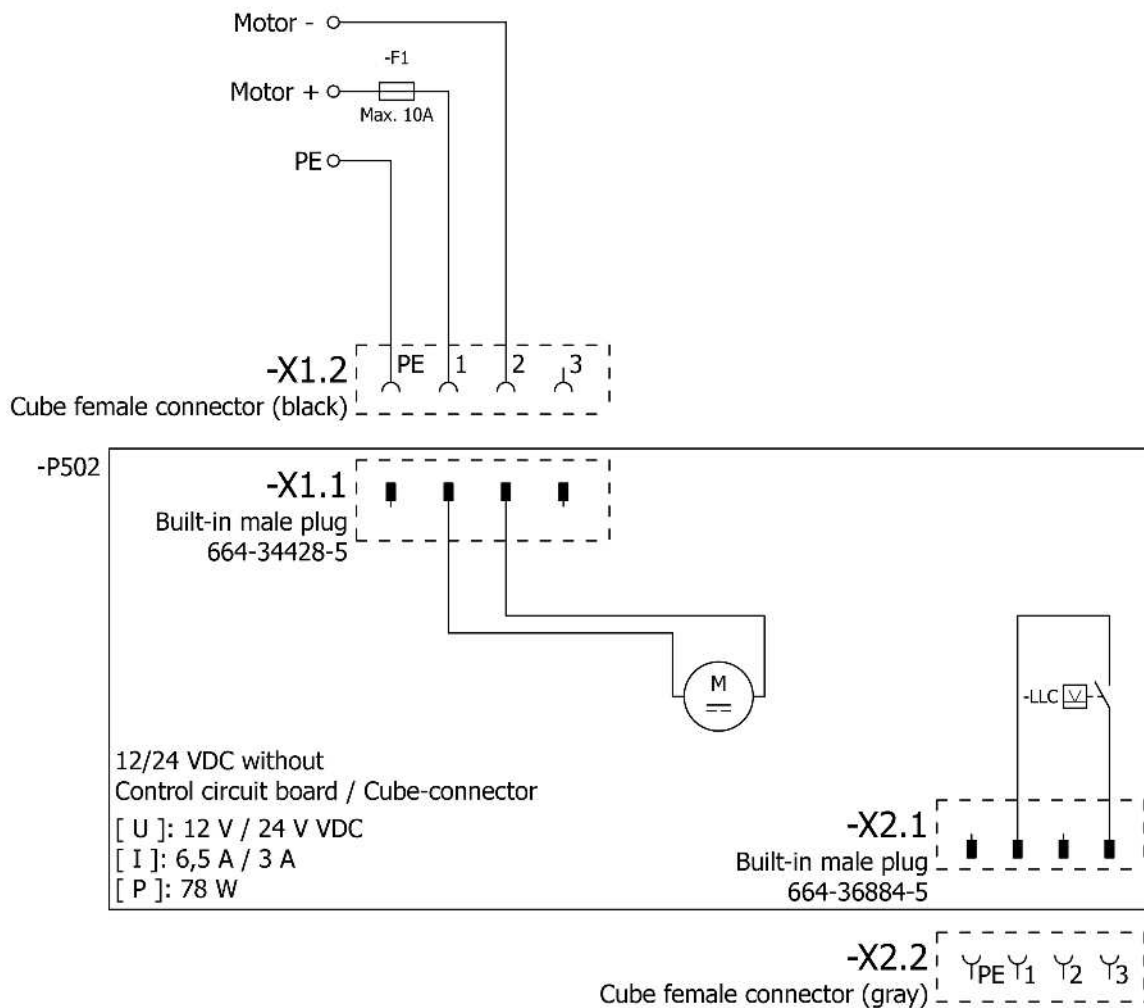

Terminal diagram 12 / 24 V DC with rectangular connector without control circuit board

15.10 Terminal diagram 12 /24 V DC with bayonet connector without control circuit board

Table 31

Terminal diagram valid for pumps with the following equipment features

- P502-1XLF-XXX-12-1A5-XX-
- P502-1XLF-XXX-24-2A5-XX-

Fig. 47

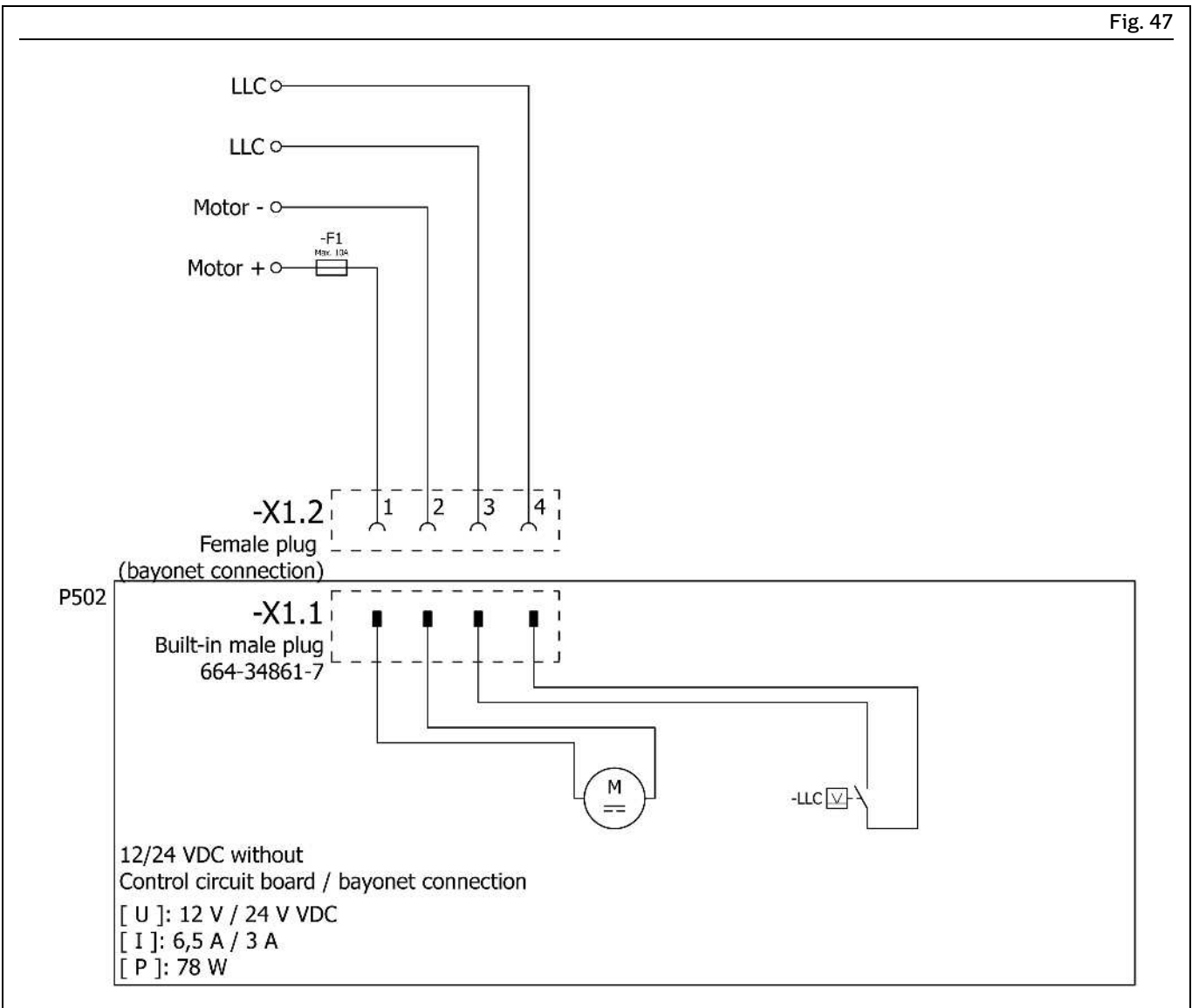

Terminal diagram 12 / 24 V DC with bayonet connector without control circuit board

15.11 Terminal diagram 12 /24 V DC with bayonet connector without control circuit board and without low-level signal

Table 32

Terminal diagram valid for pumps with the following equipment features

P502-1XN-XXX-12-1A5-XX-
P502-1XN-XXX-24-2A5-XX-

Fig. 48

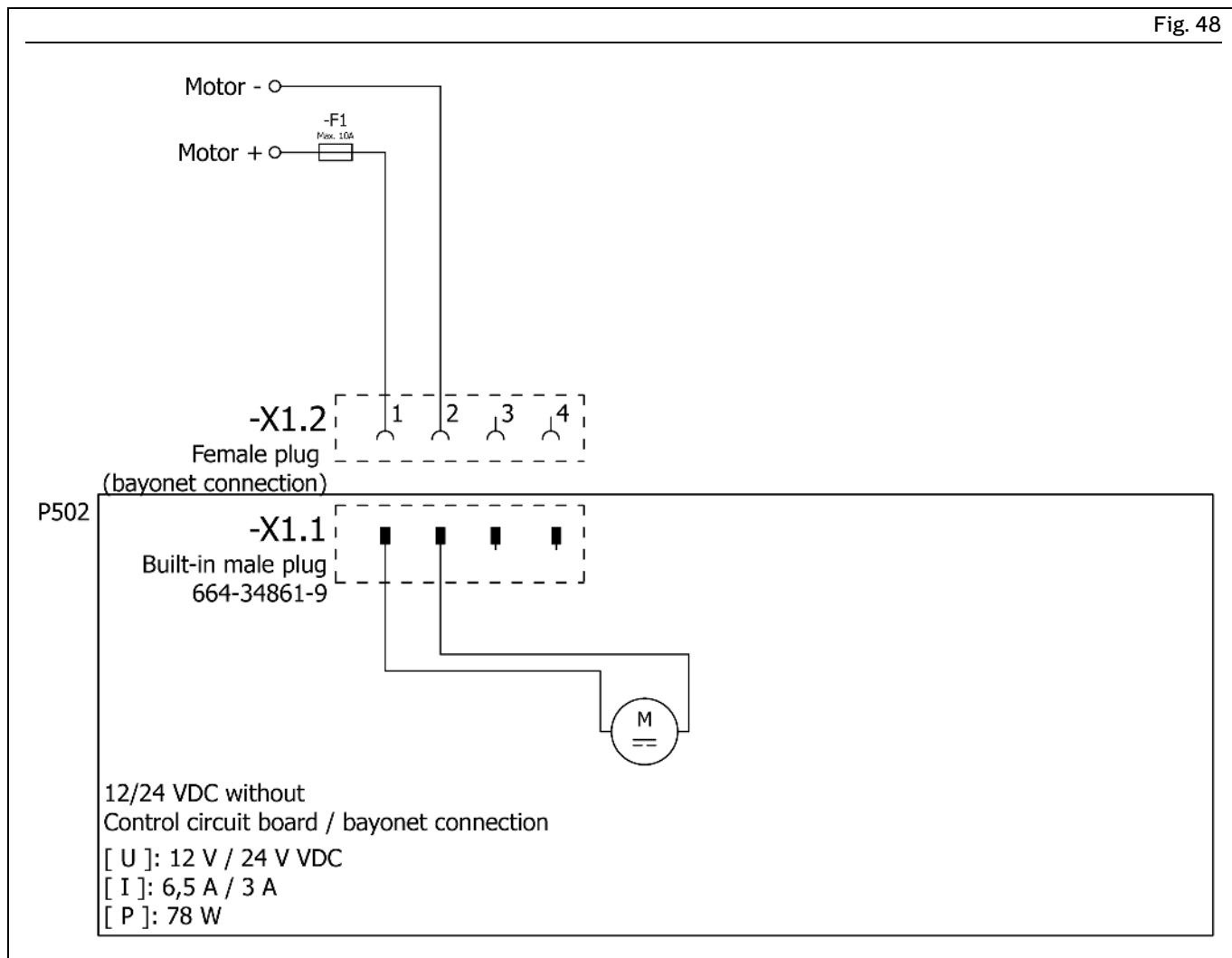

Terminal diagram 12 / 24 V DC with bayonet connector without control circuit board and without low-level signal

15.12 Terminal diagram 12 /24 V DC with rectangular connector without control circuit board and without low-level signal

Table 33

Terminal diagram valid for pumps with the following equipment features

P502-XXXX-XXX-12-1A1.10
P502-XXXX-XXX-24-2A1.10

Fig. 49

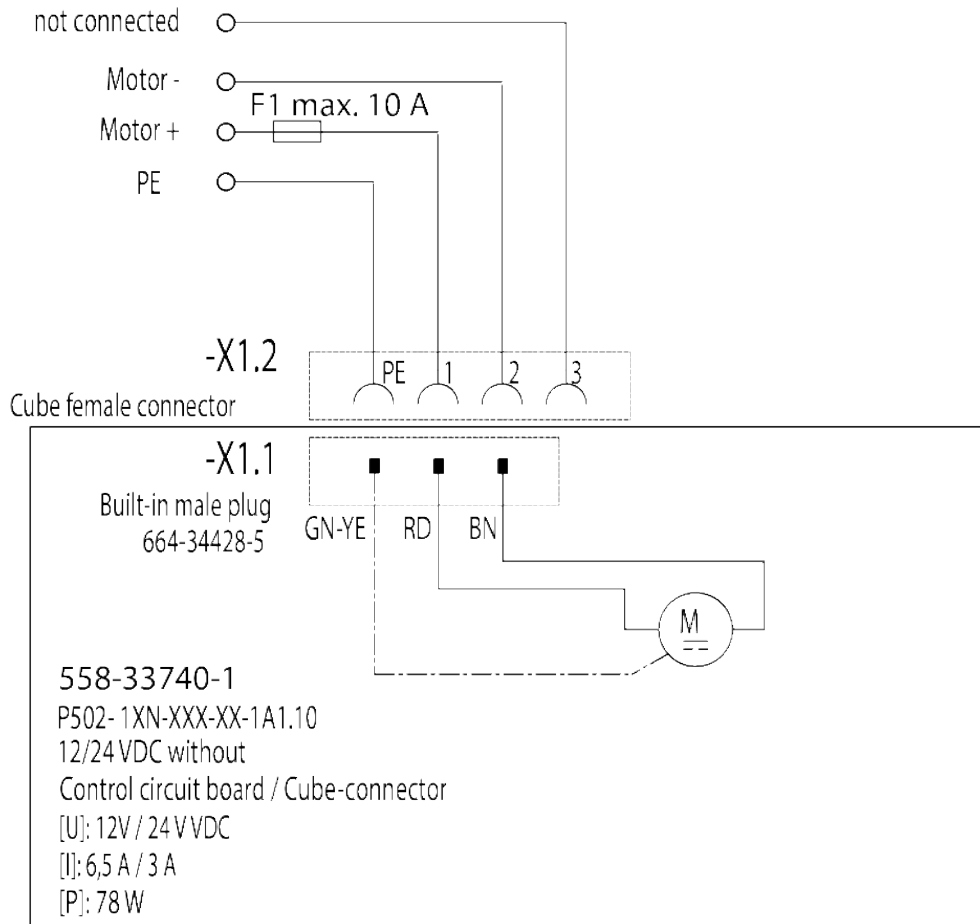

Terminal diagram 12 / 24 V DC with rectangular connector without control circuit board and without low-level signal

15.13 Terminal diagram 24 V DC with M12 connector and control circuit board

Table 34

Terminal diagram valid for pumps with the following equipment features

P502-XXXX-XXX-24-2A2.01

Fig. 50

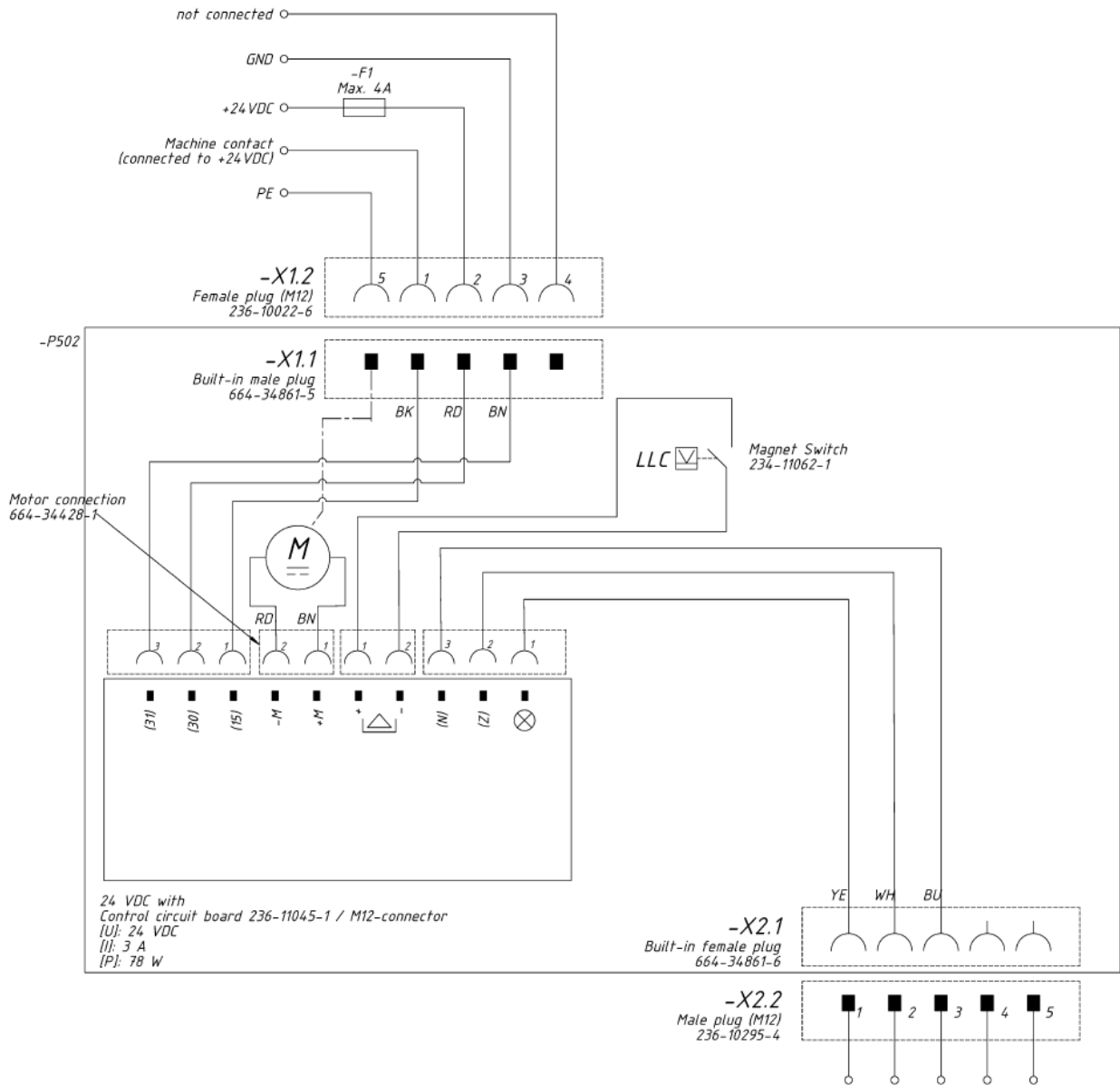

Terminal diagram 24 V DC with M12 connector and control circuit board

15.14 China RoHS Table

Table 35

部件名称 (Part Name)	有毒害物质或元素 (Hazardous substances)				
	铅 Lead (Pb)	汞 Mercury (Hg)	镉 Cadmium (Cd)	六价铬 Hexavalent Chromium (Cr(VI))	多溴联苯 Polybrominated biphenyls (PBB)
用钢和黄铜加工的零件 (Components made of machining steel and brass)	X	0	0	0	0
部件名称 (Part Name)	多溴二苯醚 Polybrominated diphenyl ethers (PBDE)	邻苯二甲酸二丁酯 Dibutyl phthalate (DBP)	邻苯二甲酸丁苄酯 Benzyl butyl phthalate (BBP)	邻苯二甲酸二(2-乙 基己基)酯 Bis (2-ethylhexyl) phthalate (DEHP)	邻苯二甲酸二异 丁酯 Diisobutyl phthalate (DIBP)
	用钢和黄铜加工的零件 (Components made of machining steel and brass)	0	0	0	0

本表格依据SJ/T11364的规定编制 (This table is prepared in accordance with the provisions of SJ/T 11364.)

- 0: 表示该有毒有害物质在该部件所有均质材料中的含量均在GB/T 26572 规定的限量要求以下。
(Indicates that said hazardous substance contained in all of the homogeneous materials for this part is below the limit requirement of GB/T 26572.)
- X: 表示该有毒有害物质至少在该部件的某一均质材料中的含量超出GB/T 26572标准规定的限量要求。
(Indicates that said hazardous substance contained in at least one of the homogeneous materials used for this part is above the limit requirement of GB/T 26572.)

skf.com/lubrication

® SKF and Lincoln are registered trademarks of the SKF Group.
™ eLube is a trademark of the SKF Group.

© SKF Group 2026
Reprint or reproduction of the contents of this information - even in part - is permitted
only with SKF's prior written consent.

PUB 951-171-009-EN 22.01.2026